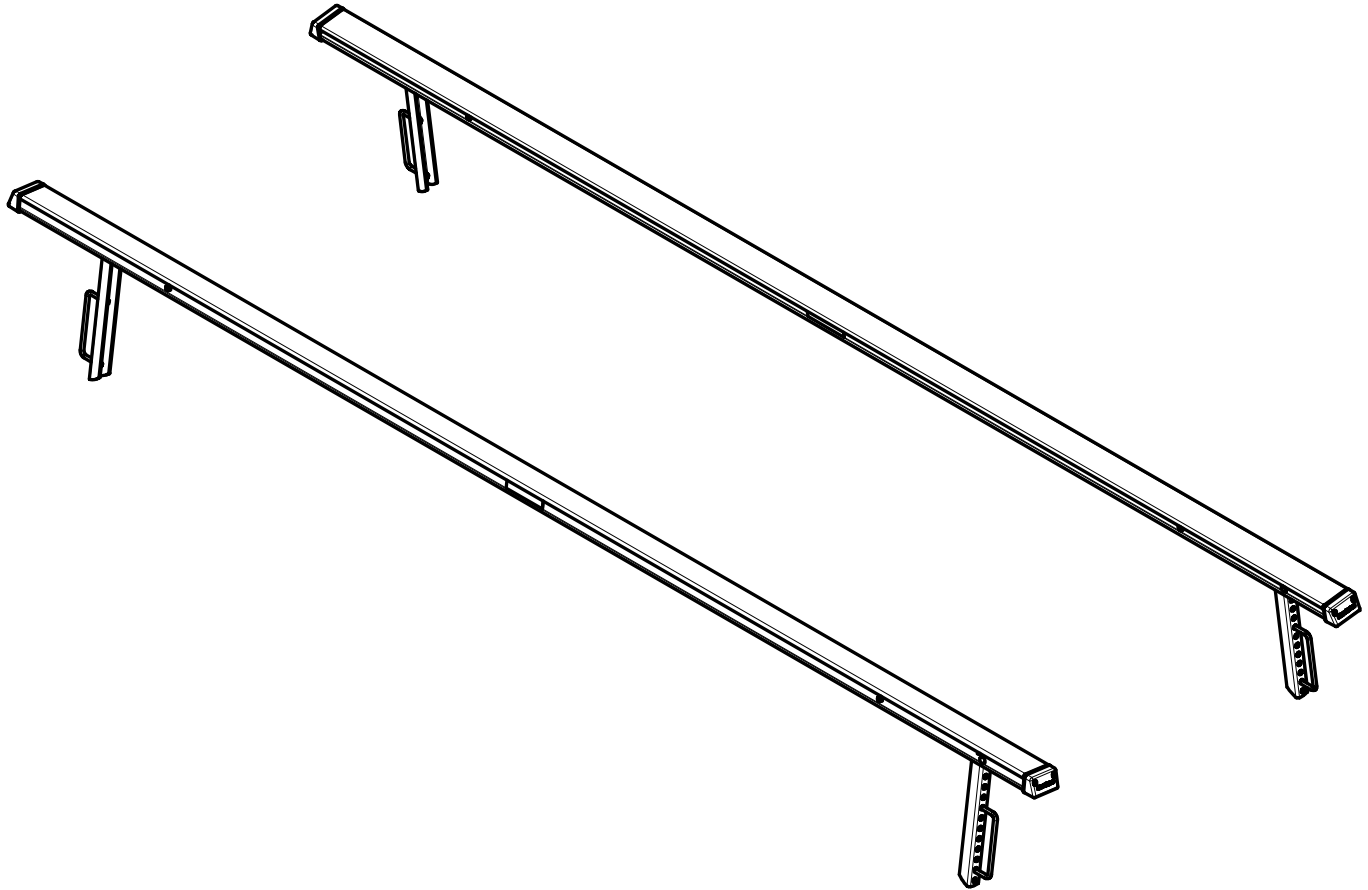

**HA0094
BUNK POLY V80-100132H HOIST SS**

This new bunk assembly is designed to be a full replacement for the carpeted wood bunks, and consists of an aluminum extrusion with a vinyl covering to protect your boat. It is designed to give the same flex and support as the carpeted wood bunks.

Installation Instructions

Remove the old bunk assemblies from your hoist by removing the 3/8 flange lock nuts and the 3/8" x 1" hex bolts that attach the carpeted bunks to the upright adjustable bunk brackets.

Now that the bunks have been removed you will now remove the hex nuts, lock washers, flat washers, and the u-bolts holding the adjustable bracket to the platform. To maintain the same height with the new poly bunks as you had with the wood ones you will need to set the adjustable brackets up one hole. These will now be replaced with the stainless steel u-bolt and flat washers along with a brass lock nut with a nylon insert. You will repeat this process on the remaining brackets.

The bunks assemblies are completely assembled at the factory and are ready to be installed on your hoist. Note that the bunk brackets installed in the new bunk system are mounted differently on each end. The one end has the bunk bracket secured in position by a dart in the aluminum extrusion and a 3/8" x 4" carriage bolt while on the other end the bunk bracket is allowed to move up and down the extrusion.

It is recommended that the end of the new bunk assembly with the bunk bracket secured be placed on the end of the hoist where the transom of the boat will be located when it is on the hoist.

Attach the new bunk assembly to the upright adjustable bunk bracket using the 3/8" x 1" stainless steel hex bolt provided with the new bunk assemblies. Secure in place with a 3/8" stainless steel flat washer and a 3/8" brass lock nut with nylon insert.

Align the other end of the bunk assembly over the upright adjustable bunk bracket on the other platform. Move the bracket until it is positioned next to the upright adjustable bunk bracket. Attach this bunk bracket to the upright adjustable bunk bracket using another 3/8" x 1" stainless steel hex bolt and secure in place with a 3/8" stainless steel flat washer and a 3/8" brass lock nut with nylon insert.

