

HA0020 Poly Bunk Assembly for V20100 Hoists

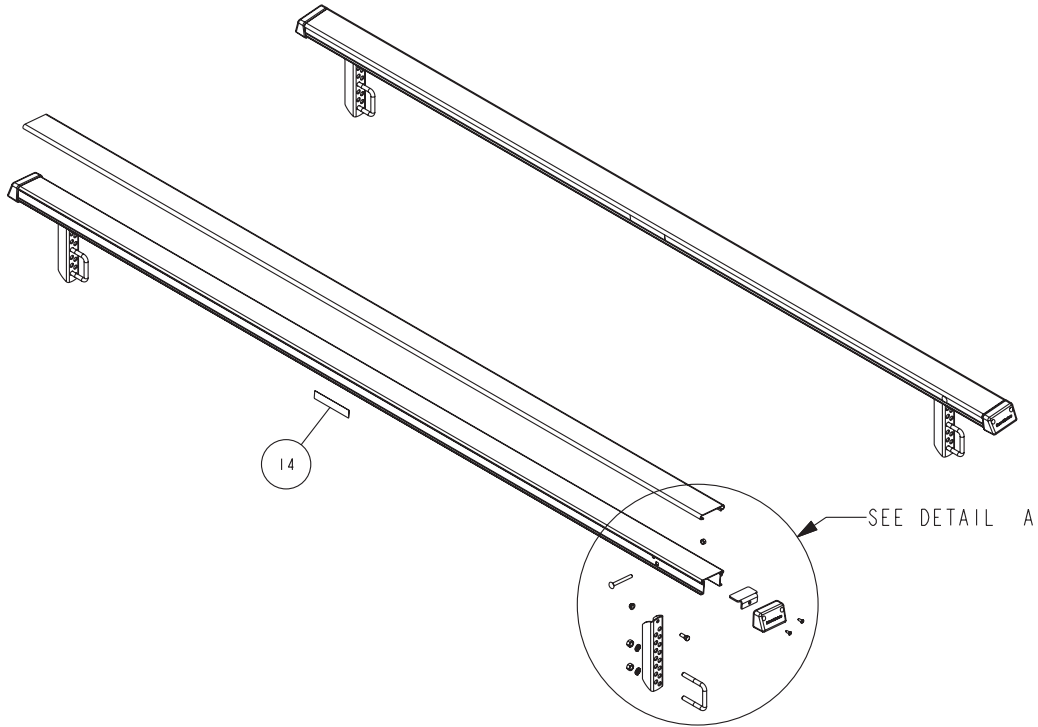

DETAIL A
SCALE 0.188

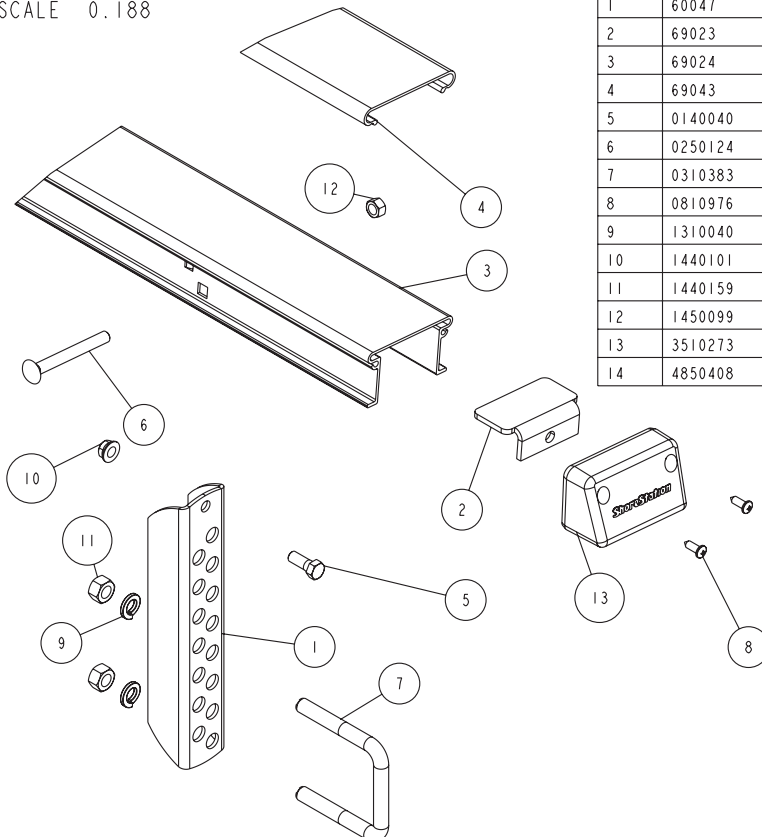

ITEM	PART #	DESCRIPTION	QTY	NOTE
1	60047	ADJ BUNK BRKT	4	
2	69023	BUNK BRACKET	4	
3	69024	EXTRUSION - AL BUNK	2	
4	69043	EXTRUSION - POLY BUNK	2	
5	0140040	HH 3/8-16 X 1 CS GR5	4	
6	0250124	CARR 3/8-16 X 3 1/2 SS GR5	2	
7	0310383	SQUARE U-BOLT	4	
8	0810976	SCREW 1/4-20X3/4 PHIL P THRD CUT SS	8	
9	1310040	LOCKWASHER 1/2 S/T MED	8	
10	1440101	HEX LOCKNUT FLANGE 3/8-16 W/T&T	4	
11	1440159	HEX NUT FINISH 1/2-13	8	
12	1450099	HEX LOCKNUT 3/8 SS W/NYLON INSER	2	
13	3510273	CAP ALUM. BUNK EXTRUSION	4	
14	4850408	DECAL NOT A STEP (SMALL)	4	

This new bunk assembly is designed to be a full replacement for the carpeted wood bunks, and consists of an aluminum extrusion with a vinyl covering to protect your boat. It is designed to give the same flex and support as the carpeted wood bunks.

It also includes new mounting hardware and longer bunk brackets. The design of the new bunk system is such that the top surface height of the new bunk will be approximately 1 1/2" lower than the carpeted bunk it is replacing. To maintain the same top of bunk height as the ones being replaced, it is necessary to also replace the bunk brackets with the longer ones provided to compensate for the height difference.

Installation Instructions

Remove the old bunk assemblies from your hoist by removing the 3/8" x 1" hex bolts that attach the carpeted bunks to the upright adjustable bunk brackets.

Measure and note how high the existing bunk brackets extend above the hoist platform. Once measured, remove the mounting hardware and bunk brackets that were used to attach the carpeted bunks to the hoist platform and discard. Replace them with the new longer bunk brackets and hardware provided with the replacement bunks. Install the new bunk brackets so they are a minimum of 1 1/2" higher than the old ones just removed. Attach them to the platform in the same locations from where the old ones were removed. Tighten when in position.

The bunks assemblies are completely assembled at the factory and are ready to be installed on your hoist. Note that the bunk brackets installed in the new bunk system are mounted differently on each end. The one end has the bunk bracket secured in position by a dart in the aluminum extrusion and a 3/8" x 4" carriage bolt while on the other end the bunk bracket is allowed to move up and down the extrusion.

It is recommended that the end of the new bunk assembly with the bunk bracket secured be placed on the end of the hoist where the transom of the boat will be located when it is on the hoist.

Attach the new bunk assembly to the upright adjustable bunk bracket using the 3/8" x 1" hex bolt provided with the new bunk assemblies. Secure in place with a 3/8" flange lock nut.

Align the other end of the bunk assembly over the upright adjustable bunk bracket on the other platform. Move the bracket until it is positioned next to the upright adjustable bunk bracket. Attach this bunk bracket to the upright adjustable bunk bracket using another 3/8" x 1" hex bolt and secure in place with a 3/8" flange lock nut.

Once both ends of the new bunk assembly are secured to the upright adjustable bunk brackets, tighten the bolts just installed but do not over tighten. The bunk assemblies must be allowed to rotate so they will conform to the boat bottom.

Repeat this process on the other bunk assembly.

Checking The Boat For Platform Clearance

The top surface of the new bunk assemblies (surface that your boat rests on) with respect to the top of the platform cross member sets 1" lower than the top surface of the old carpeted bunks just removed. To compensate for this difference raise the upright adjustable bunk brackets up one hole.

Once the bunks are installed and positioned make sure the boat does not contact the platform at any time during loading, unloading, or the raising process.

Adjustment it complete.

