

HEWITT

DOCKS - LIFTS - PONTOON LEGS

4800 LB. (114" x 127") ALUMINUM PARTS LIST LOA48-114

4 X TOP X BRACING FLATS	NA4015
2 PULL ARMS (ONE PAIR)	NAL4002
	NAR4002
2 TOP CROSS ARMS	NA4803
1 BOTTOM BACK CROSS ARM	NA4804
1 BOTTOM FRONT CROSS ARM	NA4805
1 WINCH ARM	NA4006
1 FRONT UPRIGHT	NA3006
1 FRONT TO BACK BOTTOM BRACE w/3" WRAPS	NA4020
2 BOTTOM SIDES	NA4007
2 SIDE 45° BRACES	NA4008
2 FRONT SIDE BRACES	NA4009
2 CARPETED BUNKS	LFLB121
2 2 X 6 WOOD KEEL BOARDS	LCRK
2 CENTER CROSS BRACES	NA4802
3 CROSS BEAM INNER STIFFENERS	NA4804-1
1 CROSS BEAM INNER STIFFENER	NA4804-2

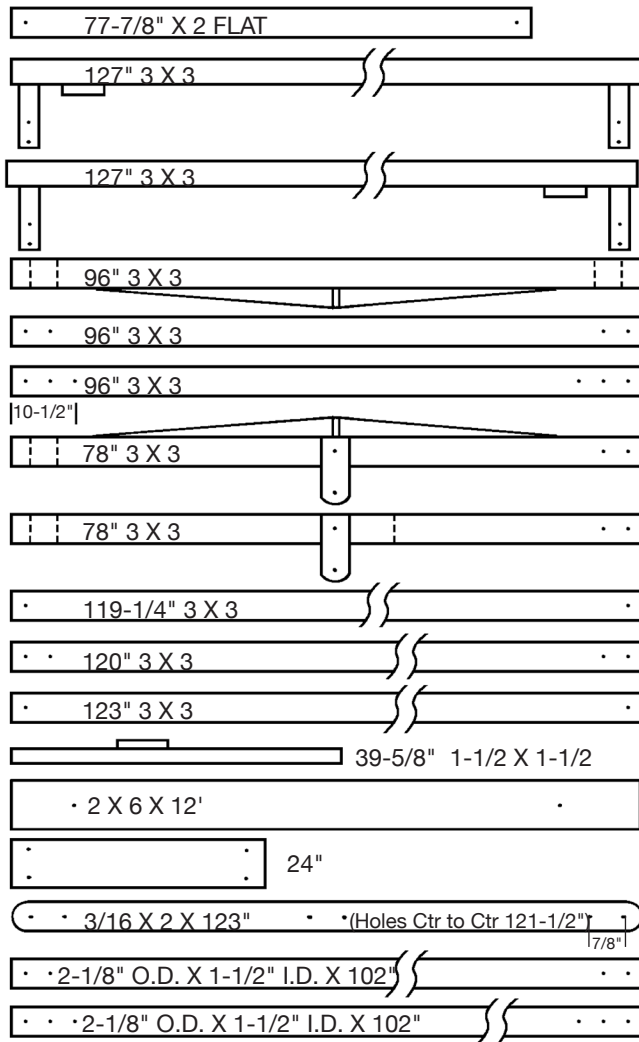

SHIPPED
INSIDE
CROSS
ARMS

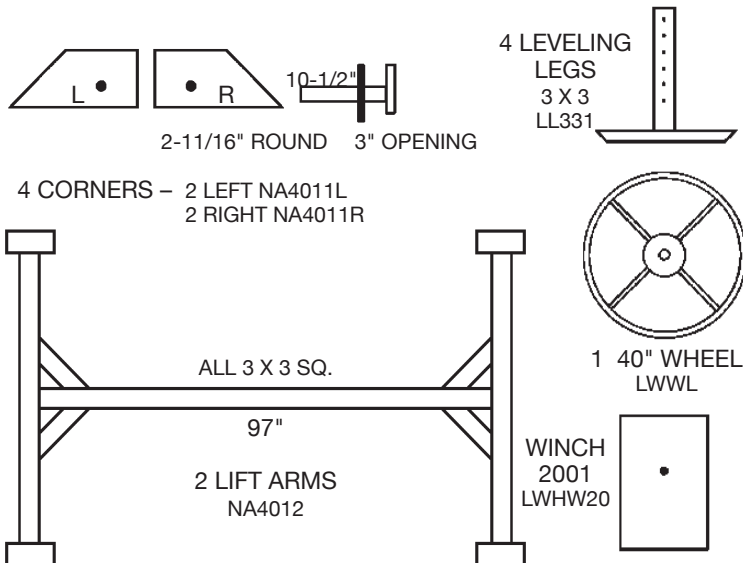

HARDWARE BAG NA4850	
1 Cable 45' x 5/16" - L1C455	2 1/2" Lock Nuts - NN12L
4 3 x 3 Aluminum Blocks - LCRB3	1 Moisture Bag
8 Cradle Side Plates - LCRSP10T	1 Assembly Instructions - NAASSY48
2 3" Sheaves - L1PS3	1 BOLT BOX - NA48BB
4 Double Walled Bushings - L1BDW@	1 3/16" SS 3-link Chain w/.39 opening - L1PC3/163L
2 3" Complete Double Pulleys - L1P3D	1 3/8" x 1-1/4" SS Bolt - NB38114FT
1 2" Teardrop Pulley - L1P2T	8 3/8" x 3-1/2" SS Bolts - NB38312G
2 Guide Pulley Side Plates - L1PSP	1 3/8" x 4" SS Bolts - NB384G
4 5" Keel Plates - LCRKP	3 3/8" x 5" SS Bolts - NB385G
4 3 x 3 Rubber Caps - D1RC3SQ	1 3/8" x 5-1/2" SS Bolts - NB38512G
1 Spinner Knob ONLY - LKNOB1	4 3/8" x 2-1/2" SS Carriage Bolts - NB38212C
4 3/8" x 3-1/2" Leg Pins w/clips - LLP3/2	8 3/8" x 5-1/2" SS Carriage Bolts - NB38512C
2 5/16" Cable Clamps - L1CC5/16	3 3/8" SS Washer - NW38FL
4 3/8" x 5" Bolts, Hard - NB385G5	74 3/8" Brass Nuts - NN38S
2 1/2" x 4-1/2" Bolts, Hard - NB12412G5	1 3/8" x 2-1/2" SS Bolt - NB38212G
1 Winch Clamp - LDLWC	

"Quality Since 1971"

HEWITT MACHINE & MFG, INC. Box 111 Nicollet, MN 56074 (507) 225-3421

www.hewittrad.com

4200 – 4800 lb. ALUMINUM LIFT Assembly Instructions

Refer to enclosed parts list for description of parts and hardware. Note: The appearance of parts in the assembly diagrams may vary somewhat for different size lifts.

STEP 1: Separate all the bolts, nuts and other hardware from the supplied bag. The $\frac{1}{2}$ " x $4\frac{1}{2}$ " bolts are used for securing the pulley assemblies into the pull arm pulley boxes. The carriage bolts are used to secure the wood cradles and keel boards to the top cross arms.

Use the shortest bolt possible at each assembly point. For easier setup, assemble the lift on a flat and level surface. Leave nuts finger tight until assembly is completed. If a bolt is difficult to insert, tap with a hammer or use a punch to line up the holes.

Refer to diagram below for Steps 2 – 4.

STEP 2: Insert leveling legs completely through each of the four corner brackets. If a longer pair of leveling legs is supplied, they should be inserted into the rear corner brackets (deep water end of the lift). Insert a leg pin into each corner bracket to set the leg height. Place a rubber cap on the top (open end) of each leveling leg.

STEP 3: Push the round tube attached to the corner brackets through the bottom ends of the lift arms and into the bottom cross arms. Secure each corner to the bottom cross arms with two bolts and nuts.

STEP 4: Connect the front and rear corners for each side to one bottom side. Secure each corner with two bolts and nuts.

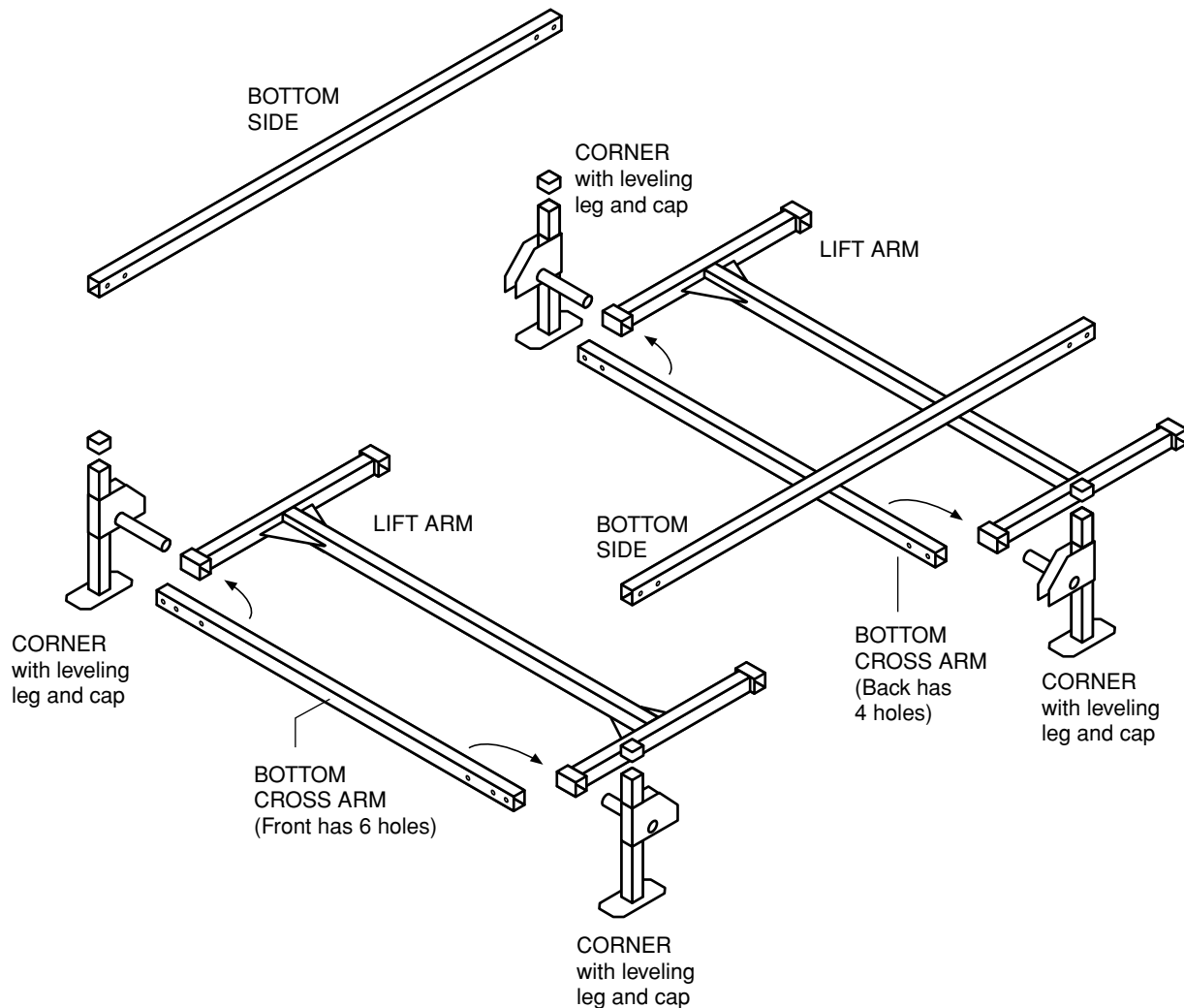

STEP 5: Pivot lift arms up into a vertical position. Caution: Temporarily brace the lift arms or have a helper hold them in the upright position to prevent injury. Assemble top cross arms and pull arms as shown. Make sure the pulley boxes on pull arms face downward. Also make sure the pulley boxes are toward the front of the lift. The front is the end with the bottom front cross arm, which has six bolt holes. Note: If you have difficulty pushing pull arms into the cross arms, use a rubber mallet or place a block of wood against pull arms and tap in with a hammer. To avoid damage, do not strike aluminum directly with a hammer. Install two bolts and nuts on front and back.

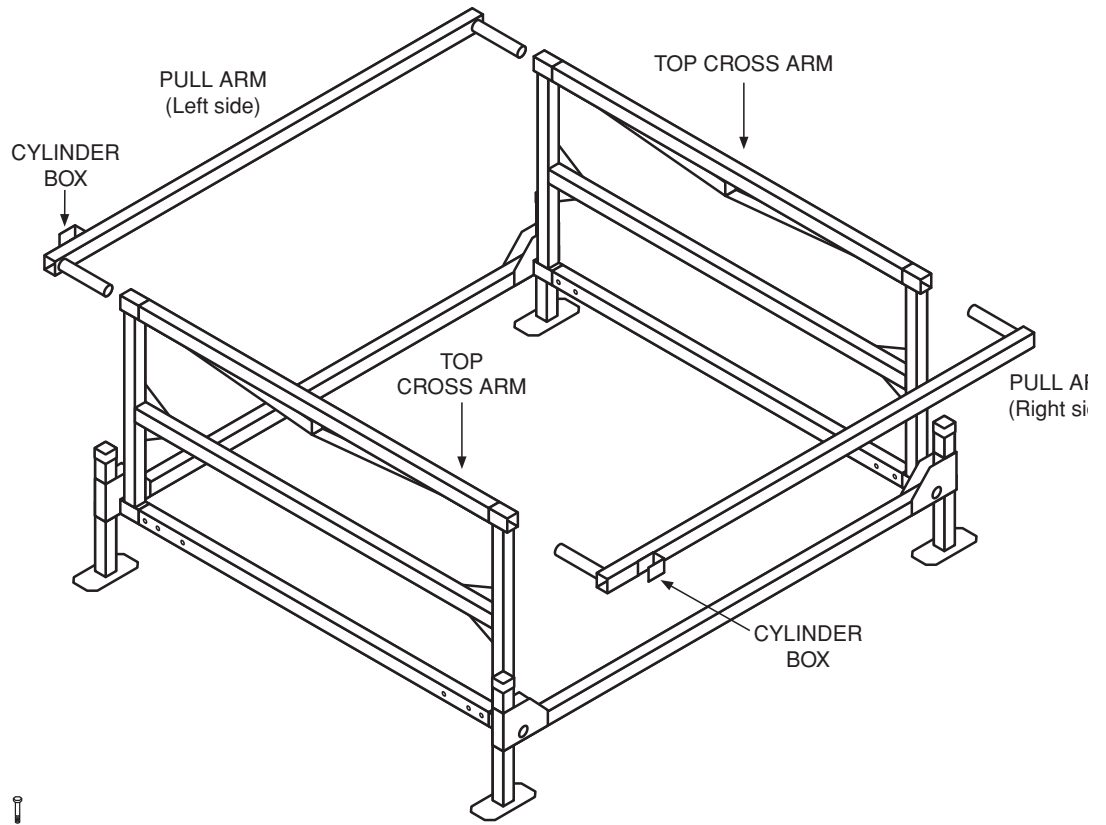

STEP 6:
Top X-bracing flats and front to back bottom brace.

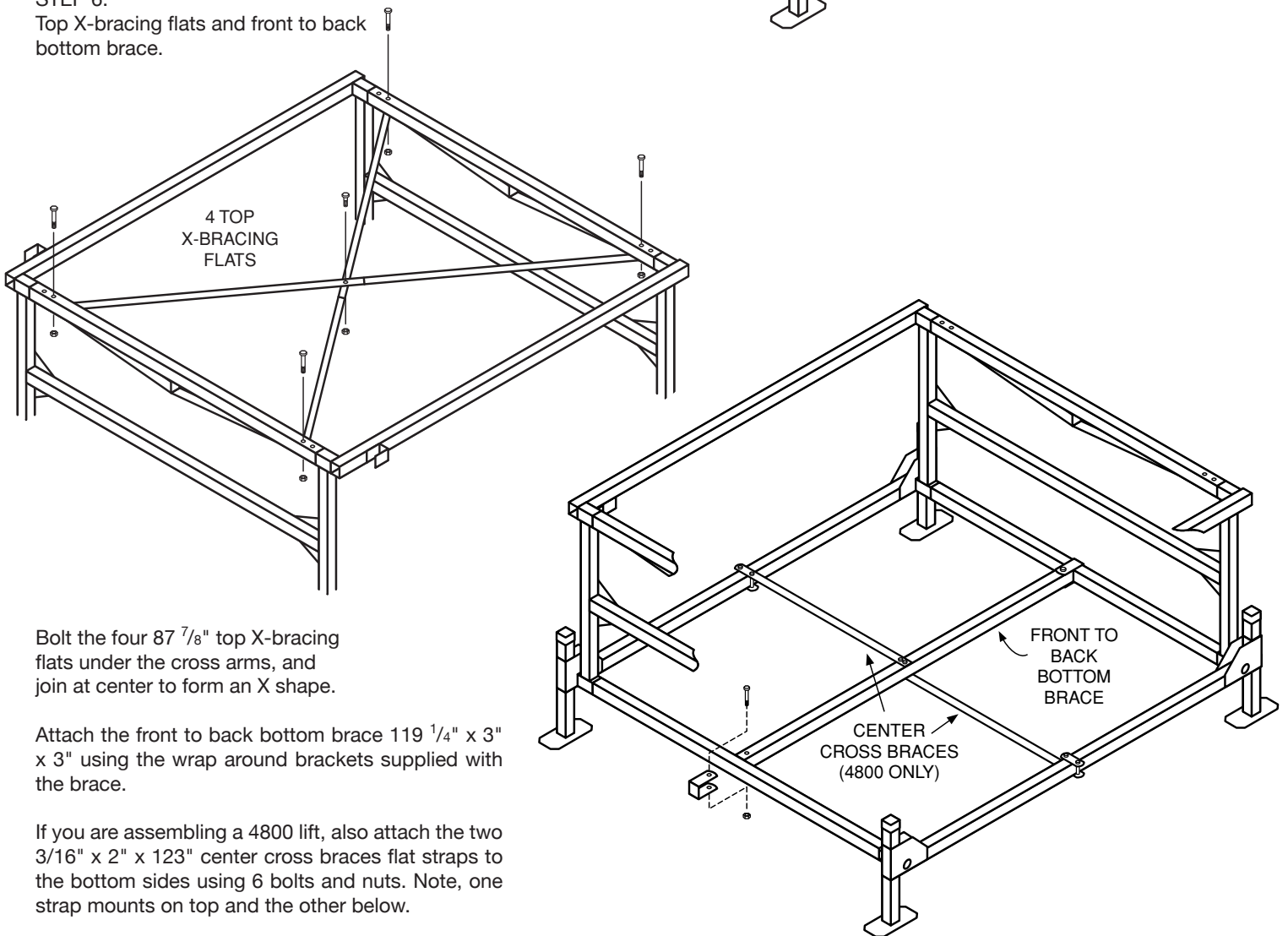

Bolt the four 87 7/8" top X-bracing flats under the cross arms, and join at center to form an X shape.

Attach the front to back bottom brace 119 1/4" x 3" x 3" using the wrap around brackets supplied with the brace.

If you are assembling a 4800 lift, also attach the two 3/16" x 2" x 123" center cross braces flat straps to the bottom sides using 6 bolts and nuts. Note, one strap mounts on top and the other below.

STEP 7. At this time, determine whether you want the winch mounted on the left or right side of the lift.

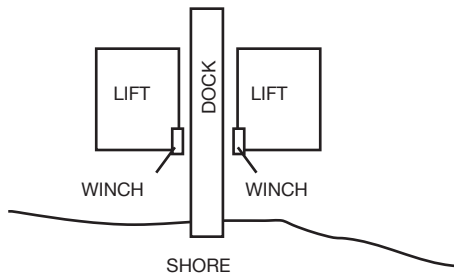

Attach the winch arm to the front corner on the side you have selected for mounting the winch. The winch arm has an identification sticker that gives the model number of the lift. Attach the front upright to the front corner on the opposite side of the lift.

STEP 8: Secure front lift arm to the winch arm and the front upright with a rope or strap while installing additional bracing, the cable and pulleys. There is one side 45° brace for each side of the lift. One end of each brace has a centered hole and the other end has an offset hole. Position the braces so the offset holes are at the rear of the lift and facing down. For each side, insert the offset hole end of the brace into the rear corner bracket and secure with a bolt and nut. The front end of the braces are attached between the plates welded to the winch arm and the front upright. When attaching the front of each brace, also attach a guide pulley assembly to the winch arm and front upright – see diagram below.

STEP 9: Attach Winch Arm Pulley on outside of Winch Arm with bolt and nut – see diagram below.

STEP 10: Attach front side braces to bottom front cross arm and the front upright and winch arm. Position braces so the spacer blocks are towards the inside of the lift.

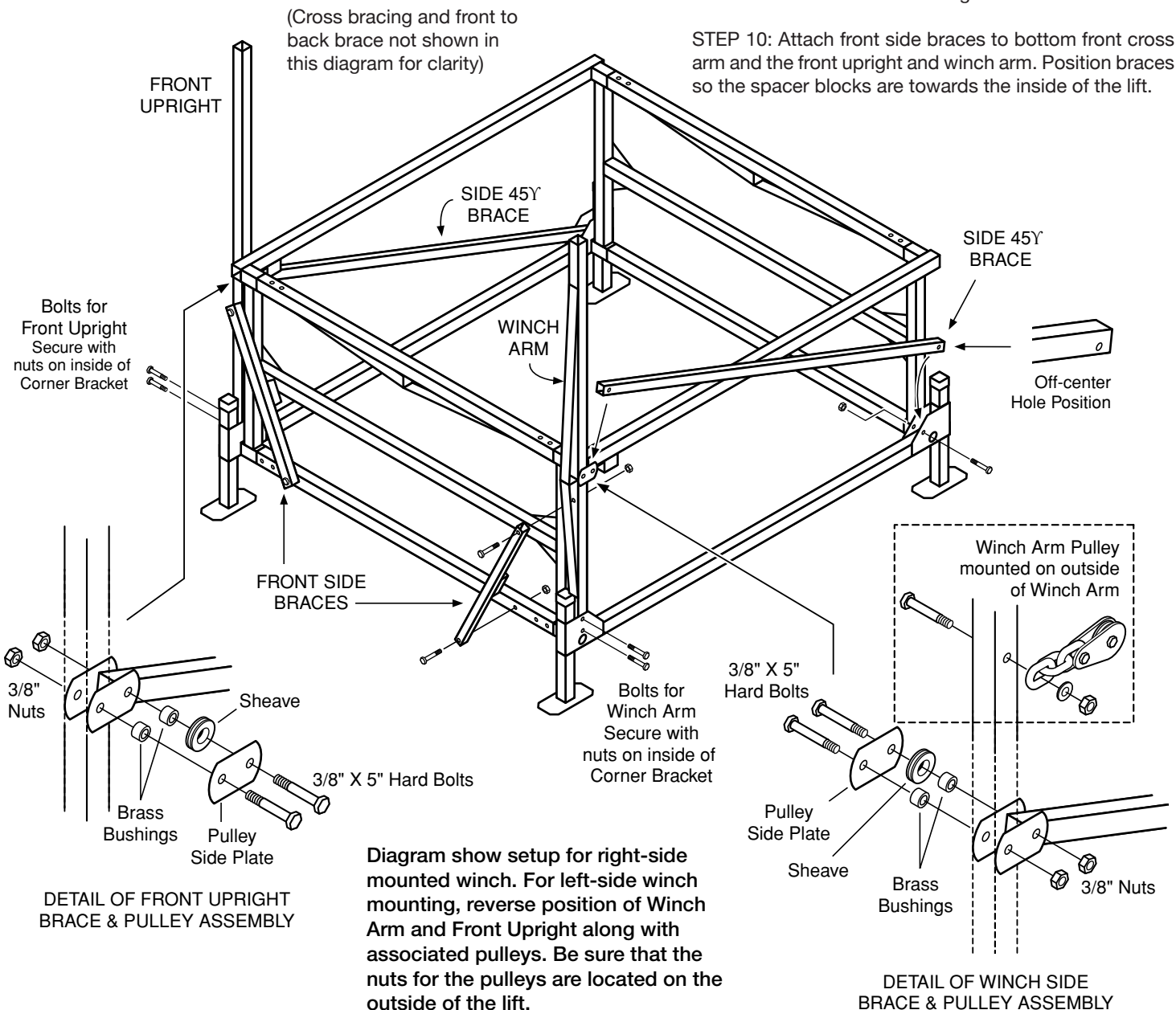

STEP 11: Bolt the complete double pulley assemblies into the pulley boxes on the pull arms, **making sure they are slanted toward the outside** of the lift as shown. Use the two 1/2" x 4 1/2" bolts with lock nuts. **Do not over-tighten. These pulleys must move up and down freely.**

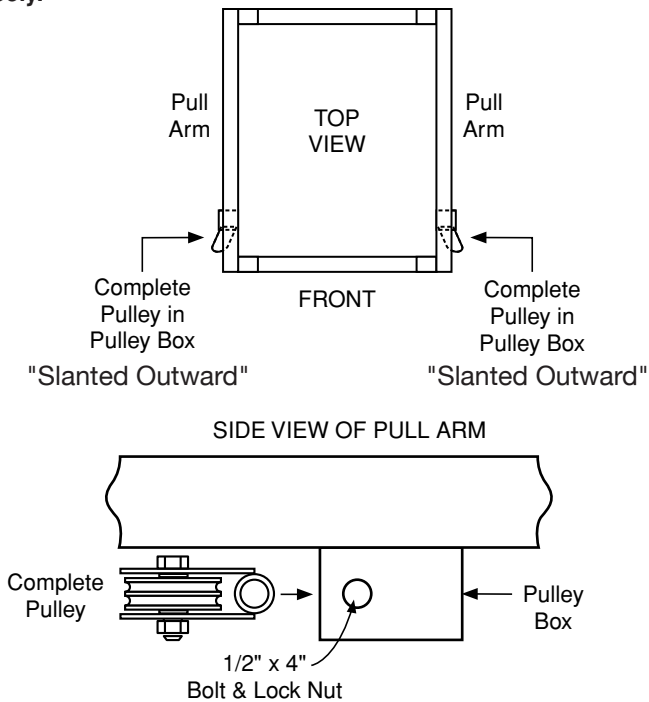

STEP 13: Attach cable to the winch cable drum using the clamp already attached to the drum.

Cable installation: The winch turns clockwise when looking at the winch wheel. Route the cable over the winch drum in the direction the drum will rotate and under the cable clamp. A minimum of three full wraps of cable should be present before winch load is applied.

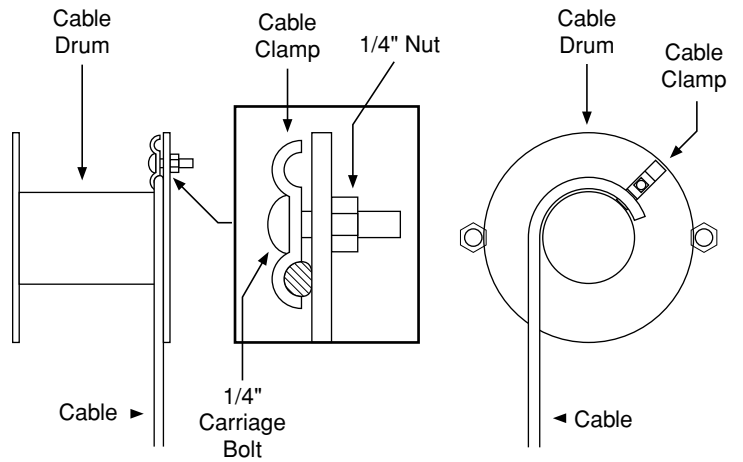

STEP 12: Mount the winch onto the side of the winch arm that faces the back of the lift. Attach winch with the aluminum winch reinforcement plate, two bolts and nuts as shown. Tip: If installing a canopy, the canopy extension leg should be inserted into the winch arm while mounting the winch. See canopy assembly instructions for details.

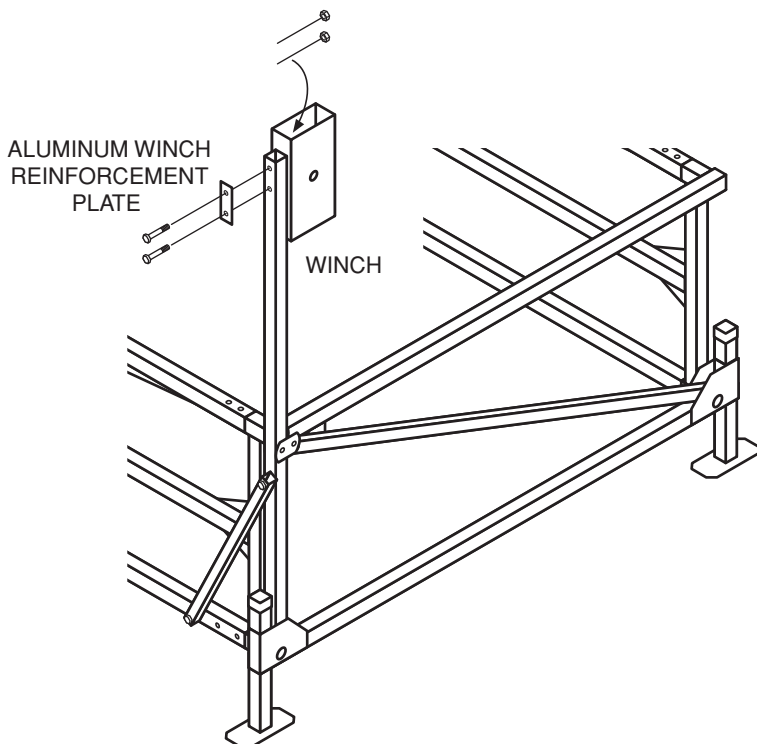

STEP 14: String cable down from the winch and run cable through the pulleys in the numbered order shown below. Wrap cable end around the winch arm twice, as shown, and secure with cable clamps provided.

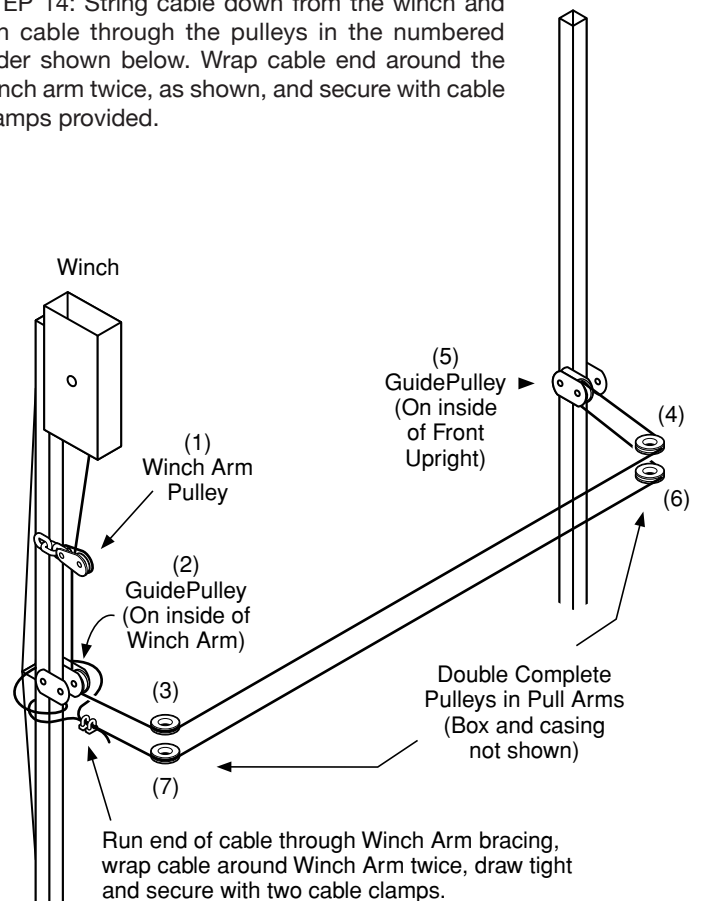

STEP 15: Install the spinner knob to the winch wheel as shown below.

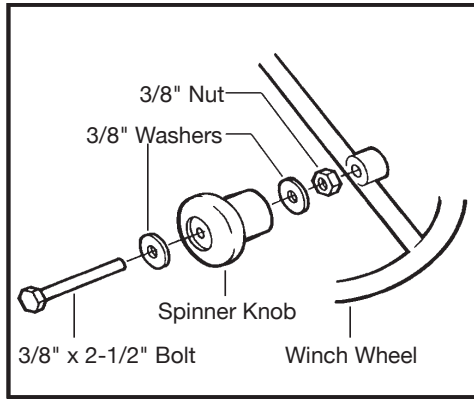

STEP 17: Mount the carpeted bunks onto the aluminum blocks. Install the bunks and keel boards using carriage bolts as shown below.

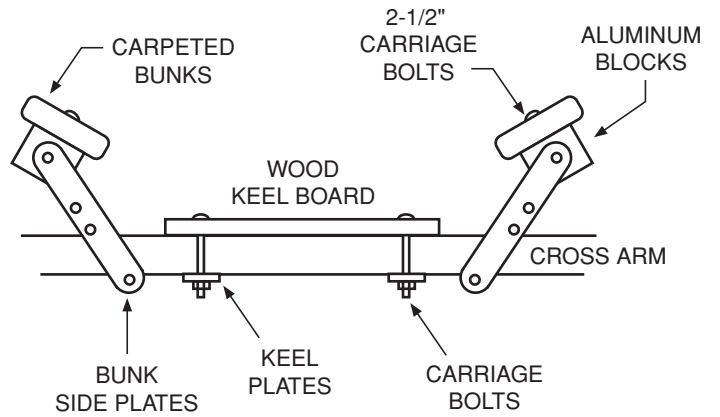

STEP 16: Remove the hex bolt and washer from the threaded shaft on the winch. Grease the threads on the winch wheel so it is able to turn freely. Turn the wheel clockwise on the threaded shaft until it is tight against the winch. Replace washer and hex bolt to secure wheel to winch.

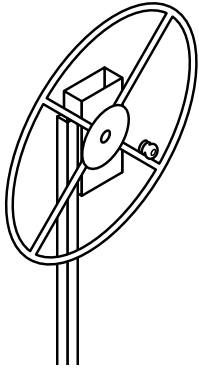

For further details, see the instruction sheet supplied with your winch.

FULLY ASSEMBLED

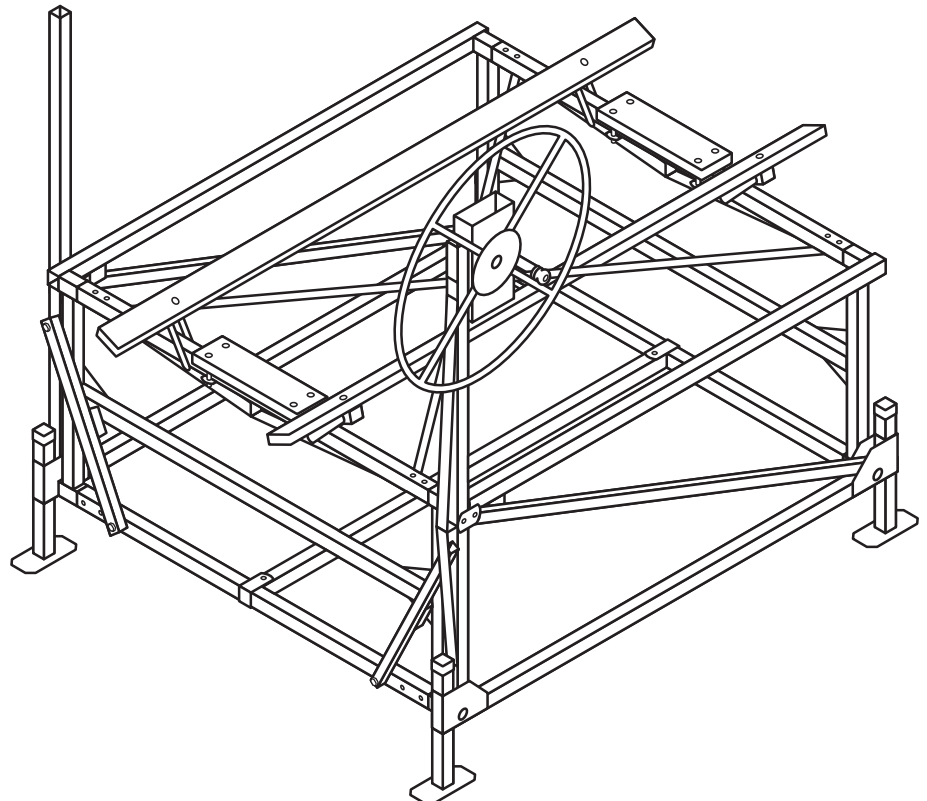

STEP 18: Tighten all bolts and nuts, and make sure that all pulley wheels turn and pivot freely.

STEP 19: Lastly – Turn the winch wheel clockwise until the slack cable is tight. **Be sure the cable windings are contained within the drum.** Remove any temporary strap or rope that was used to hold the lift arms upright during assembly.

WINCH OPERATION: To lift, turn the winch wheel clockwise. The brake ratchet pawl should produce a clicking sound. The winch will hold the load at any position. To lower the load, turn the wheel counter clockwise. NEVER LIFT HUMAN BEINGS ON THE LIFT. NEVER ALLOW HUMAN BEINGS UNDER THE LIFT OR LOAD AT ANY TIME.

WARNING: To avoid injury, never lift the ratchet pawl from the ratchet wheel. It must stay in contact with the wheel at all times.

NOTES:

- Grease the cable and the bushings yearly for longer life.
- Periodically check that the pulleys are turning freely.
- When installing lift, the bed should be nearly level with the rear of lift, only slightly lower than the front.
- When placing the boat on the lift, make sure the boat is brought forward as far as possible without over running the lift. (The stem should be close to the back of the rear cross arm)
- When operating the lift, DO NOT, continue to crank the winch after the lift bed is fully down. Doing so will cause the cable to loosen on the winch drum causing the cable to tangle when rewinding.
- Allow your boat to float off of the lift framework completely before attempting to load or unload your boat from the lift. Do not power on or off.

WARRANTY

New HEWITT-built boat and pontoon lifts carry a 15 year conditional warranty on all aluminum and aluminum welds, and a 5 year conditional warranty on canvases, excluding fading.

HEWITT Machine and Manufacturing, Inc. further warrants all other parts used on HEWITT-built lifts and accessories, purchased new by the original owner, to be free from defects in the material and workmanship under normal use for a period of 24 months from the date of purchase (excluding components and options which carry their own manufacturer's warranty, wherein that warranty will apply). There is no other express warranty. HEWITT Machine and Mfg. Inc. is not liable for incidental or consequential damages or injuries of any kind due to installation, removal, use, misuse, misapplication or improper selection of one of our purchased or displayed products. HEWITT agrees to repair or replace only defective parts returned to the factory (prepaid) and deemed defective by HEWITT. Warranty is void when misuse or neglect is the cause.

Specifications are subject to change without notice.

"Quality Since 1971"

HEWITT MACHINE & MFG, INC. Box 111 Nicollet, MN 56074 (507) 225-3421
www.hewitt-roll-a-dock.com