

Lift Leg Battery Box Tray

Instructions

Part #: 1024401

Parts List			
ITEM	QTY	PART NUMBER	DESCRIPTION
1	1	1024400	Wdmt - Lift Leg Battery Box Tray
-	1	1024402	Bolt Bag - Lift Leg Battery Box Tray
2	1	1021908	Cap Press-In 1.125x1.625 Silver No Logo
3	1	1024393	Battery Box Tray with Strap - 7.8125 x 14
4	8	1002608	Washer Flat 5/16 SS
5	4	1002453	Bolt Hex 5/16-18 X 1.0 SS
6	4	1001807	Nut Hex 5/16-18 Brass
7	2	1014218	Screw Self-Drilling Hex Head 1/4 x 1 SS
8	2	1014564	Hose Clamp 72 Dia (not shown)

Failure to follow instructions may result in personal injury and may invalidate the applicable warranty.

Step 1. Determine the location for your battery making sure the power cable will be long enough to reach and the battery tray will not interfere with your dock or your lift.

Step 2. Set the hold down battery box tray on the weldment lift/dock leg tray and secure as shown using four 5/16 x 1 hex bolts, eight washers and four nuts.

Step 3. Take the hose clamps and open them by un-screwing them and wrap them around your lift or dock leg.

Step 4. Set the weldment lift / dock leg tray in the desired position on your lift or dock leg. Position the hose clamps so there will be one clamp above the tube and one below (top and bottom).

Step 5. Tighten the hose clamps, make sure to position the hose clamps so the tightening screw will not interfere with the operation of your lift.

Step 6. Set your battery on the hold down battery tray (DO NOT DROP onto tray) and secure with nylon strap.

Note: You can also use the $\frac{1}{4}$ x 1" Self Drilling Screws to secure the battery tray to the lift / dock leg, as long as the screws will not interfere with the operation of the lift or dock.

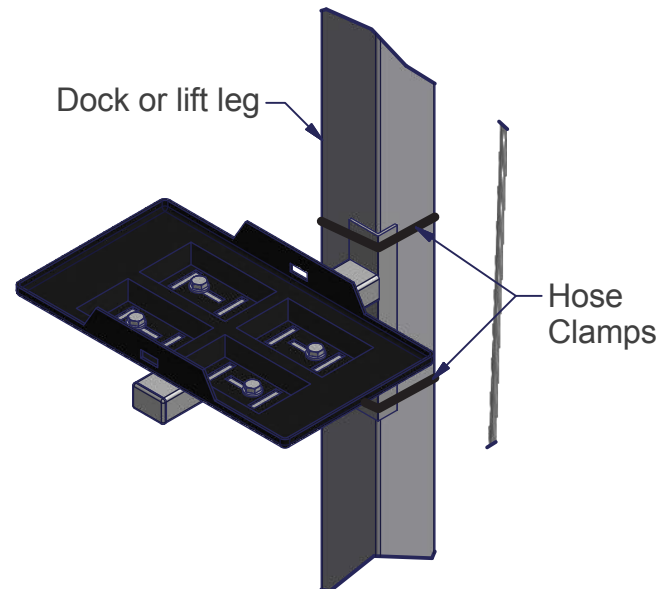
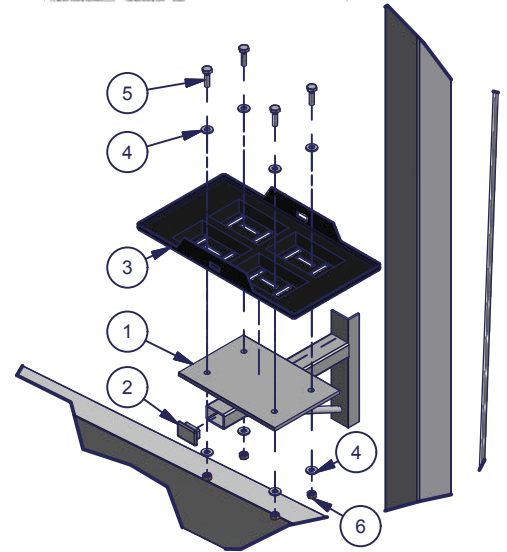

CAUTION DO NOT use the battery tray for a step.