

SSP Pontoon Kit

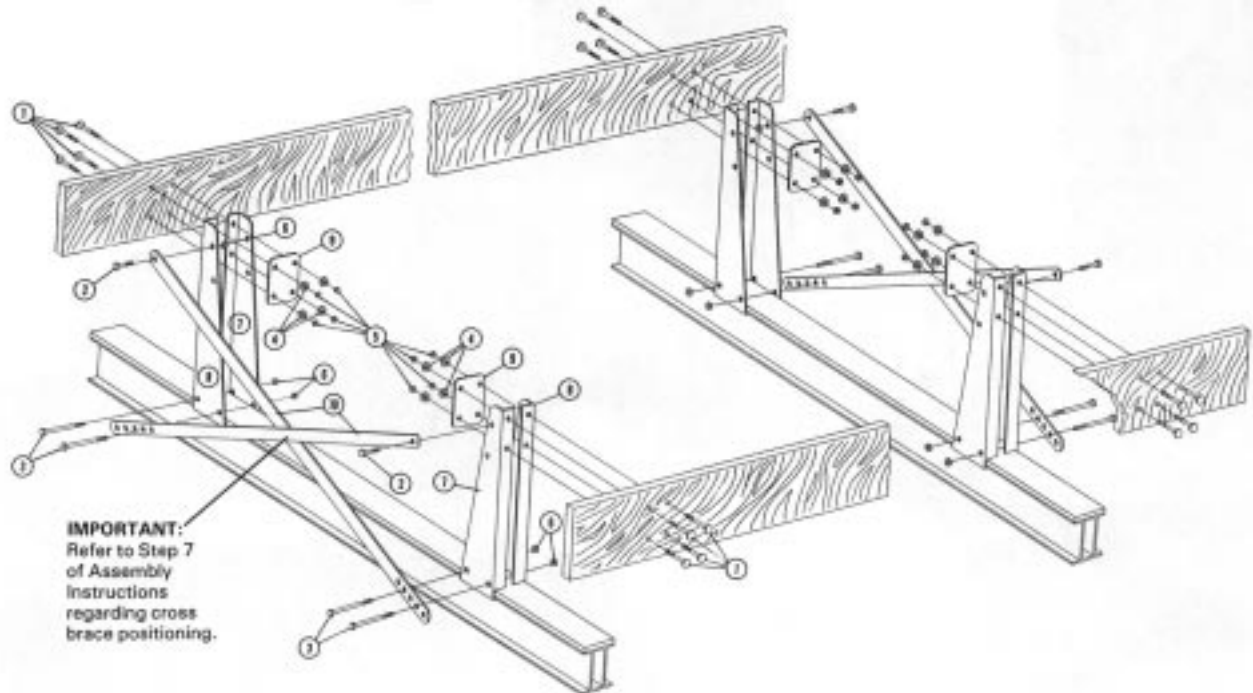

REF#	PART#	DESCRIPTION	QTY
1	0210126	3/8" X 2-3/4" CARRIAGE BOLT	16
2	0140092	1/2" X 1-1/4" HEX BOLT	4
3	0120130	1/2" X 6-1/2" HEX BOLT	8
4	1340095	3/8" FLAT WASHER	16
5	1410109	3/8" HEX NUT	16
6	1440102	1/2" FLANGE LOCK NUT	12
7	A230	MOUNTING BRACKET - RIGHT ...	4
8	A231	MOUNTING BRACKET - LEFT	4
9	A232	SPLICER PLATE	4
10	A233	CROSS BRACE	4

Assembly Instructions

Proper selection of locally purchased lumber for this pontoon kit is very important. The 2X10 or 2X12 planks should be as long as the pontoon platform in order to adequately support the entire deck properly.

Upright Mount Bracket Installation:

Install a left and right mounting bracket in all four (4) corners of the hoist platform with the flat surface of the mounting brackets facing out. Install the lower outside 1/2" X 6-1/2" hex bolt and flange lock nut finger tight.

Wooden Plank Installation:

It is very important to properly install the planks to the upright bracket resulting in proper positioning of the pontoon boat on the hoist. The larger the pontoon boat the more important it becomes that the center balance point of the pontoon boat be positioned over the center of the hoist.

Install the wooden planks accordingly as follows:

1. Measure from the bottom of the pontoon to the bottom of the pontoon deck and add approximately 1" (22" be adequate for most pontoon boats.)
2. With the measurement taken in Step and the information preceding this paragraph, position the planks up to the upright brackets and mark one (1) of four (4) mount holes.
3. Use the splicer plate (A232) as a template to mark and drill the holes for the 3/8" carriage bolts.
4. Install the planks to the uprights with the 3/8" X 2-3/4" carriage bolt, flat washer and hex nut finger tight with the splicer plates inside the uprights.
5. Measure the distance between the pontoon tubes at the narrowest point and subtract approximately 2".
6. Position the upright on the hoist platform equally on all four (4) corners and maintain the distance measured in Step 5.
7. Install the cross braces at the top of the upright with the 1/2" X 1-1/4" hex bolt and 1/2" flange lock nut finger tight in either the top or second hole from the top depending upon the clearance needed to clear the motor box or transom mount brackets of the pontoon boat. Install the cross braces in the bottom of the upright bracket with the inside 1/2" X 6-1/2" hex bolt and 1/2" flange lock nut finger tight.
8. Double check the width measurement required in Step 5 and the height measurement taken in Step 1. If they are, tighten all fasteners.
9. Position the pontoon on the hoist. The deck should be resting on the planks with the pontoon slightly above the hoist platform as well as properly balanced fore and aft.