



Owner's Manual

LSV20100B

Lakeshore Lift Vertical

LSV20100B

LS5000B leg bundle
LS5001B post bundle
LS1502B cradle bundle 100"
LS1503B spreader bundle
LS1504B bunk bundle
LS1505B accessory box
LS2005B wheel

READ CAREFULLY - FAILURE TO FOLLOW INSTRUCTIONS AND SAFETY RULES MAY RESULT IN SERIOUS INJURY

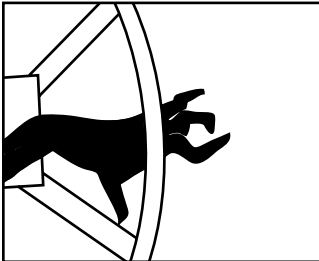

⚠ WARNING

DO NOT ATTEMPT TO STOP SPINNING WHEEL.
Serious personal injury could result.

Lift Wheel must be turned clockwise for lifting.
NEVER raise lift by turning wheel counterclockwise.
Doing so will result in an uncontrolled spin down,
which could lead to cable failure and serious injury.

Z117

⚠ CAUTION

DO NOT CRANK PAST STOP POSITION.

When raising lift be aware that when moving components contact frame you have reached maximum height.
Turning wheel past this point may cause personal injury and will cause damage to lift that is not covered by warranty.

Z119

⚠ WARNING

DO NOT OPERATE THIS HOIST WITHOUT FIRST STUDYING THE OWNER'S MANUAL.

1. Before operating this lift be sure to understand all operating procedures and safety precautions.
2. **NEVER** operate lift with people on board boat or near any part of lift.
3. **NEVER** work or play on, around or under lift.
4. **NEVER** exceed the rated capacity of lift. Doing so may cause lift to fail.
5. Before use visually inspect **SHEAVES** and **CABLE** for wear or fraying. Follow proper maintenance procedures.

Failure to follow these procedures could cause lift to fail and result in death or serious personal injury.

Z116

Manufacturers of Lakeshore Products

855 East Chicago Road, Quincy, MI 49082

www.lakeshoreproducts.com • tel: 517.639.3815 • fax: 517.639.4576

STEP 1

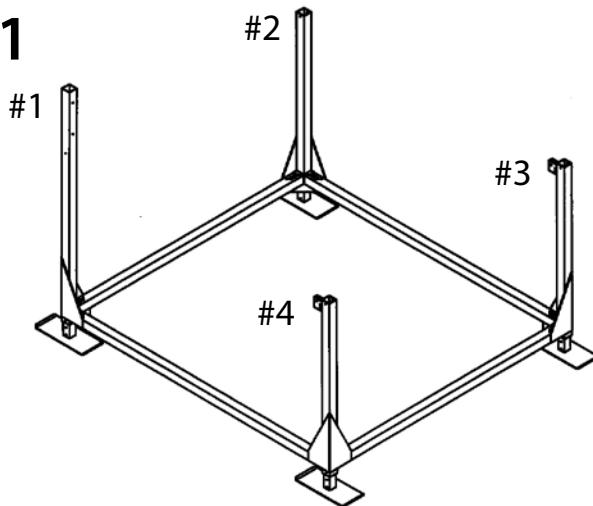

Mainframe Posts (A,B,P,R)*	4
Legs (S)	4
100" Side Mainframe Spreaders (O)	2
100" F/R Mainframe Spreaders (N)	2
Bolt Package Step 1	1

* denotes letter on exploded view

1.1 attach legs

Slide 4 legs into the 4 mainframe posts using:

- 4 - 3/8 x 4" bent clevis pins
- 4 - hairpin cotters

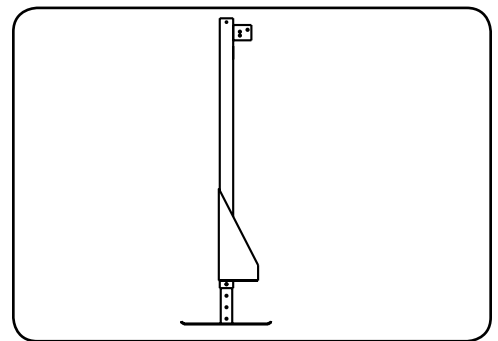

1.2 arrange Mainframe Posts

Stand all 4 posts on a flat area, arranged as shown above.

1.3 attach Side Mainframe Spreader Tubes

Position one 100" Side Mainframe Spreader Tube between Post #1 and #4. Bolt in place using:

- 2 - 3/8 x 4-1/2" hex bolts
- 2 - 3/8 flat washers
- 2 - 3/8 nylon lock nuts

at each post. Repeat with other 100" Side Mainframe Spreader between Post #2 and #3.

NOTE: The Side Mainframe Spreader Tubes are 100" long with the large slots in each end.

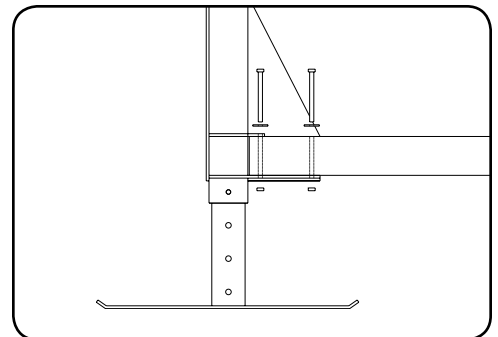

1.4 attach Front/Rear Mainframe Spreader Tubes

Position one F/R Mainframe Spreader Tube between Post #1 and #2. This is the front of the lift. Bolt in place using:

- 2 - 3/8 x 4-1/2" hex bolts
- 2 - 3/8 flat washers
- 2 - 3/8 nylon lock nuts

at each post. Repeat with other F/R Mainframe Spreader between Post #3 and #4. This is the rear of the lift.

STEP 2

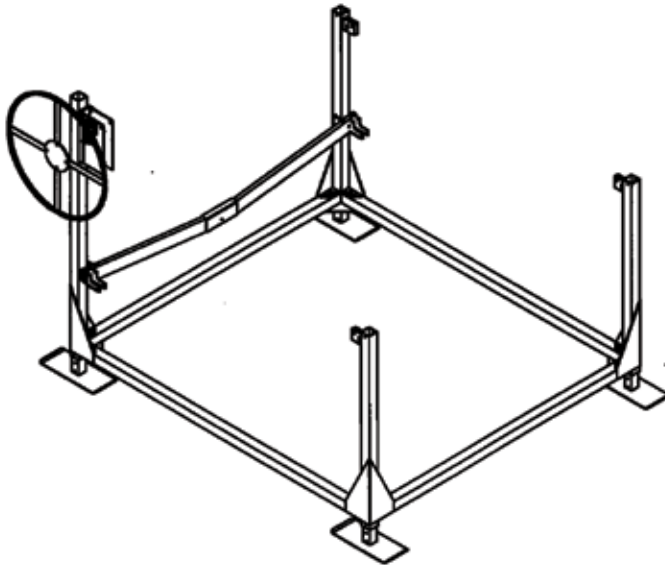

Cradle Front (K)	1
Winch (H)	1
Wheel 41" (I)	1
Wheel Shaft Adapter(I)	1
Bolt Package Step 2	1

2.1 attach Winch

Attach winch to Post #1 - the tallest one with:

- 2 - 3/8 x 5" hex bolts
- 2 - large aluminum washers
- 2 - 3/8 nylon lock nuts

Be sure to place the washers under the heads of the bolts on the outside of the post.

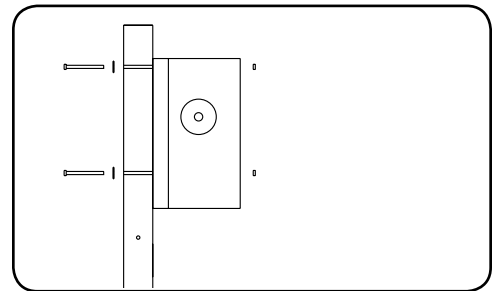

2.2 attach Wheel

Remove the 4 Carriage Bolts from the Wheel Mounting Plate. Align the 4 holes in the Mounting Plate with the holes on the Shaft Adapter.

Attach using the 4 Carriage Bolts and Locknuts provided.

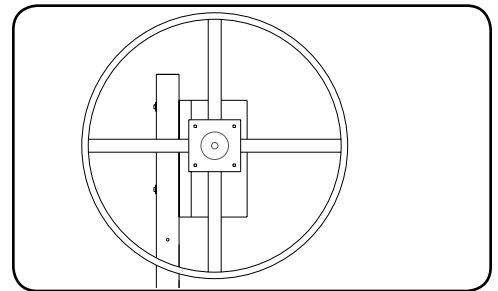

2.3 attach Front Cradle

Position the Front Cradle between Post #1 and #2.

NOTE: the Front Cradle has a cable with a loop on only one end.

Attach the loop end to Post #2 in the low hole closest to the post with:

- 1 - 1/2 x 2" hex bolts
- 1 - 1/2 nylon lock nuts

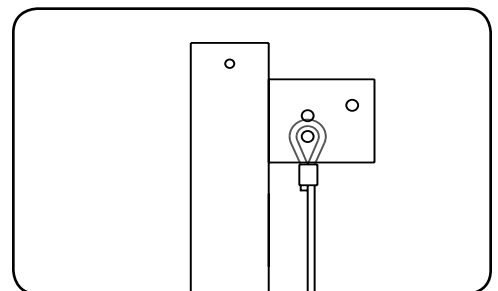

2.4 attach Cable

Locate the two holes drilled thru the winch drum. One hole is larger than the other. Select the appropriate hole for the size of your cable. Loosen the set screw in the center of that hole with the 5/32" Allen wrench supplied with your lift. Because this set screw is located in the side of the drum, you will have to reach it thru the hole in the side of the winch. Thread the straight end of the cable thru the appropriate hole so that the end just sticks out of the other side, tighten the set screw, and begin to wind the cable up around the drum. Turn the winch clockwise. You should hear a clicking sound. After the first few rises of the lift, check to be sure the set screw is still tight.

STEP 3

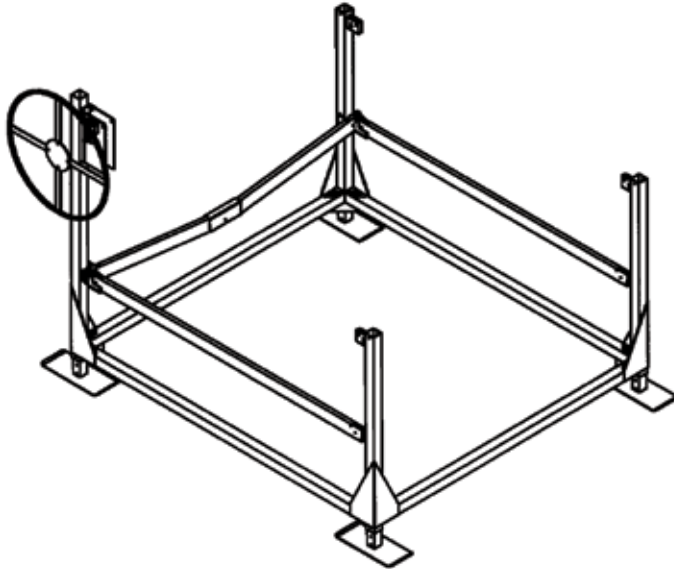

Cradle Spreaders (L)	2
Bolt Package Step 3	1

3.1 attach Cradle Spreader

Attach one end of the Cradle Spreader tube to the Front Cradle near Post#1. Use:

- 4 - 3/8 x 2-1/2" hex bolts
- 4 - 3/8 nylon lock nuts

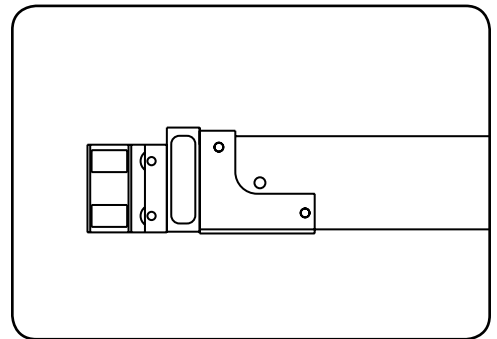

3.2 attach Side Cable

Feed the end of the cable that hangs down through the holes in the Mainframe Spreader Tube by Post #1 and pull out the bottom of the lift. Using:

- 1 - Shackle

Unscrew the Shackle Pin and put the Shackle through the loop at the end of the cable. Securely thread the pin into the Shackle and tighten to secure the cable.

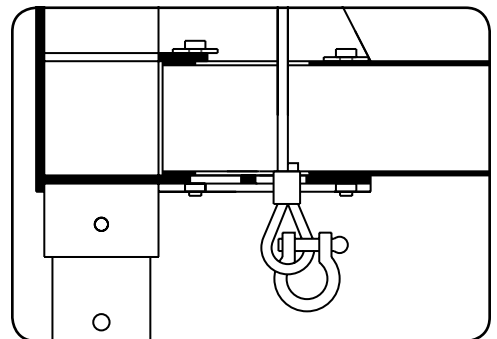

3.3 attach Side Cable

Take the opposite end of the cable that comes up out of the Spreader and attach it to the top of Post #4. Use the holes furthest away from the post and attach using:

- 1 - 1/2 x 2 hex bolts
- 1 - 1/2 nylon lock nuts

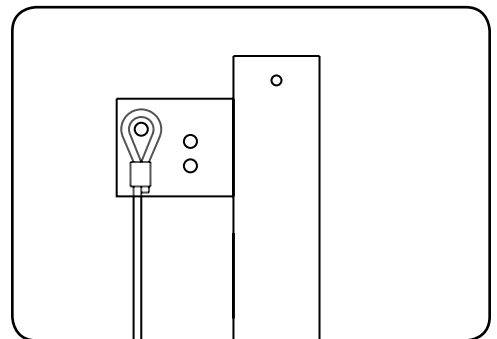

3.4 repeat

Repeat for other Cradle Spreader.

STEP 4

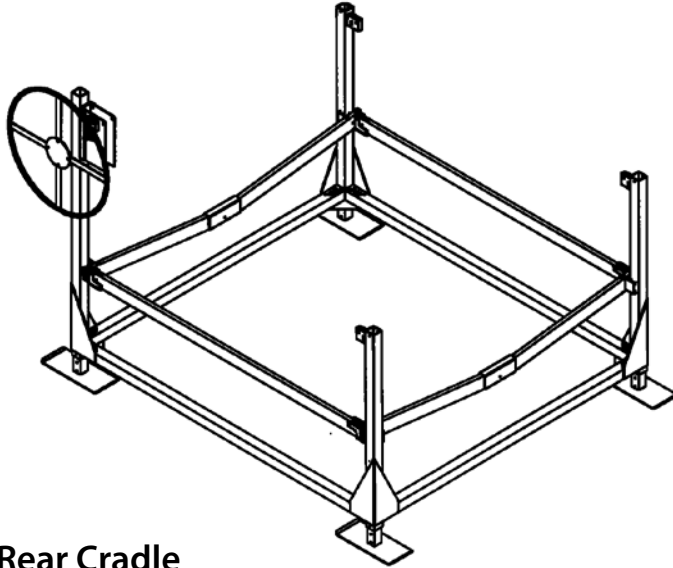

Rear Cradle (Q)	1
Bolt Package Step 4	1

4.1 attach Rear Cradle

Set the Rear Cradle on the ends of the Cradle Spreader tubes. Attach to the Spreaders using:

- 4 - 3/8 x 2-1/2" hex bolts
- 4 - 3/8 nylon lock nuts

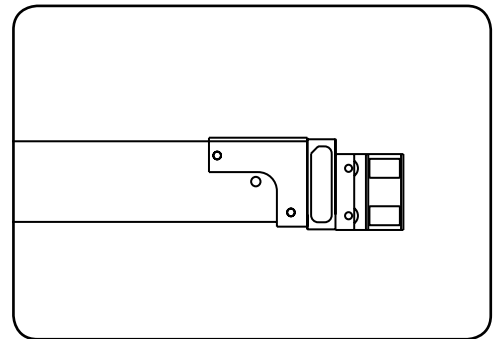

4.2 attach Cables at bottom

Feed the two down cable ends through the side Mainframe Spreader Tubes and out the bottom of the lift. Attach using:

- 2 - Shackles

Unscrew the Shackle Pin and put the Shackle through the loop at the end of the cable. Securely thread the pin into the Shackle and tighten to secure the cable.

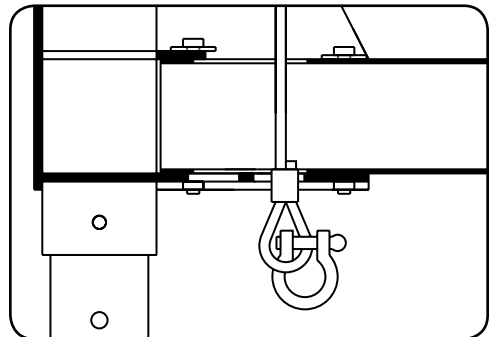

4.3 attach Cables at top

Attach the two up ends of the cables to Post #3 and #4. Use the holes closest to the post, starting with both cables in the lowest holes. If the rear cables appear too loose, try moving one cable, or both to the next hole. Bolt in place using:

- 1 - 1/2 x 2 hex bolts
- 1 - 1/2 nylon lock nuts

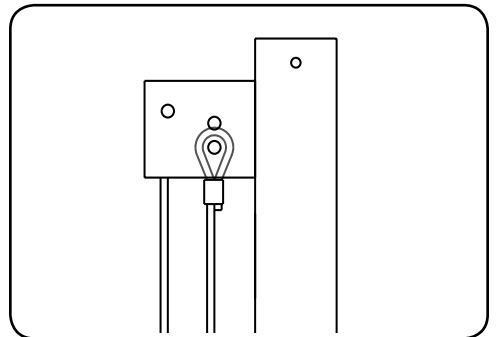

STEP 5

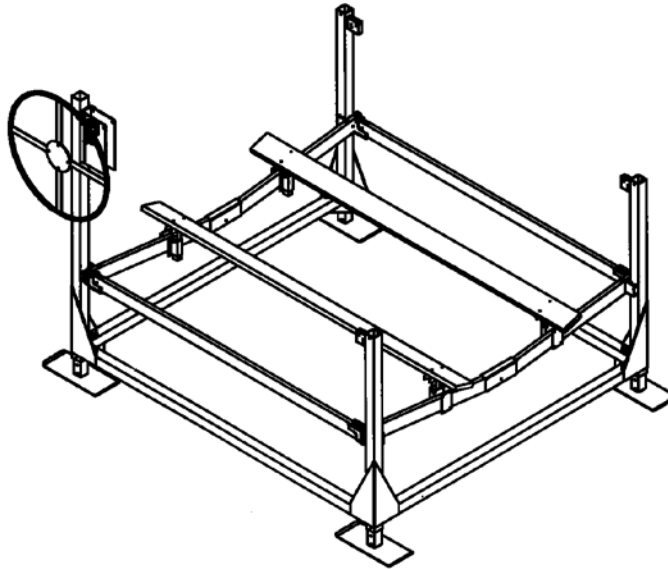

Bunk Assembly (C)	2
Bolt Package Step 5	1

5.1 attach Bunks

Attach Bunk Sockets and Bunk Socket Plates making sure to place the sockets towards the inside of the lift.

- 16 - 3/8 x 2-1/2" hex bolts
- 16 - 3/8 nylon lock nuts

Install the Bunks by sliding into the Bunk Sockets and securing with:

- 4 - 3/8 x 2-1/2" clevis pin
- 4 - hairpin cotter

5.2 adjust Bunks

Move your lift into the water.

Adjust the height and position of the Bunks so that they cradle your boat and keep the bottom of the boat off the Cradle.

5.3 adjust Legs

Adjust the lift Legs so that the lift sits level in the water, within 3" to 6" is acceptable.

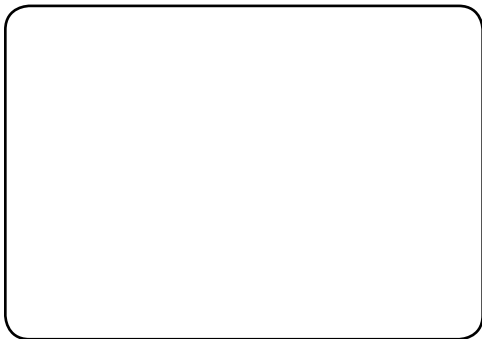

NOTE

Never over crank the winch. Once the lift has reached its highest point, further cranking will damage the lift.

NOTE

The wheel needs to thread on and off the shaft to activate the brake. This shaft should be greased yearly to ensure proper operation.

Extreme care should be taken not to cross thread and damage the threads on the wheel hub. This will void your warranty.

hints

- A. Shallow water ? Remove the adjustable legs to make the lift sit even lower in the water. In this position the Cradle can be placed lower than on any other lift available.
- B. Deep water ? Extension legs are available in 4', 5', and 6' lengths. Call your Dealer for pricing.

important

- A. The winch and brake mechanism will work better if the wheel shaft is greased yearly. This task has been simplified by the addition of a grease fitting on the wheel shaft right behind the red wheel.
- B. Your Lakeshore Jet Lift will only protect your personal watercraft if the craft is lifted well above the level of the water. In larger lakes or during storms, large waves may lift the craft from the lift or tip the lift over, causing damage both to the craft and the lift. You must take precautions to protect your craft and lift from these conditions. If your craft suffers damage from high waves, LSP, Inc. will not accept responsibility for such damage.
- C. Inspect your lift often for signs of wear or improper operation. Be aware of normal cranking force. Any increase in cranking force is a sign that something is wrong. DO NOT USE the lift if any parts are worn or damaged, replace immediately.
- D. Pay attention to the condition of your cable. A frayed or rusted cable can lead to failure of the lift. Replace it immediately. Greasing the cable, especially the first 5' where it enters the winch, can extend its life.
- E. A second caution decal is provided in the accessories box. If after assembly the decal is not easily seen then install the extra decal so that anyone using the lift can read it. NEVER let anyone operate the lift unless they are familiar with all safety rules.
- F. NEVER let anyone play on, around, or under the lift.

LS1505B accessory package

BPV30B	Bolt PackageV30/40B	1
W5	Winch	1
20865	Wheel Shaft Adapter	1
20676	Bunk Socket	4
20678	Bunk Socket Plate	4
DEM3535	3-1/2" x 3-1/2" Red Cap	4

BPV30B bolt package

20848	STEP 1	
Y418	3/8" x 4-1/2" hex bolt	16
Y451	3/8" hex lock nut	16
Y452	3/8" flat washer	16
CP1	3/8 x 4" bent clevis pin	4
HPC	1/8" hairpin cotter	4
20849	STEP 2	
Y420	3/8" x 5" hex bolt	2
Y451	3/8" hex lock nut	2
Y508	1/2" x 2" hex bolt	1
Y551	1/2" hex lock nut	1
Y552	large aluminum washer	2
20890	5/32 allen wrench	1
20850	STEP 3	
Y410	3/8" x 2-1/2" hex bolt	4
Y451	3/8" hex lock nut	4
Y508	1/2" x 2" hex bolt	2
Y551	1/2" hex lock nut	2
SHACKLE	3/8" shackle	2
20851	STEP 4	
Y410	3/8" x 2-1/2" hex bolt	4
Y451	3/8" hex lock nut	4
Y508	1/2" x 2" hex bolt	2
Y551	1/2" hex lock nut	2
SHACKLE	3/8" shackle	2
20852	STEP 5	
Y410	3/8" x 2-1/2" hex bolt	16
Y451	3/8" hex lock nut	16
CP	3/8 x 2-1/2" clevis pin	4
HPC	1/8" hairpin cotter	4

Ten/Two Year Limited Warranty

LSP, Inc. (Seller) warrants the aluminum structure on docks and lifts of its manufacture to be free from defects caused by faulty material or poor workmanship. Seller will, at its option, repair or replace any such goods found on examination by Seller, to be defective under normal use and service within ten years from date of purchase. Upon discovery of any such defect, Buyer must notify Seller in writing of defect and provide proof of purchase. Seller warrants cast aluminum parts, mechanical components, and hardware for two years.

Seller shall not be held responsible for repairs or modifications to its docks or lifts unless authorization has been obtained from Seller. This warranty does not cover damage caused by incorrect assembly or adjustments, overloading, improper use, neglected maintenance, alterations, or damage caused by accident, ice, salt water, or acts of God.

Components obtained from other manufacturers and used in Seller's products will be covered under the manufacturer's warranty and shall not be the responsibility of the Seller.

Seller's responsibility under this warranty shall be the repair or replacement of defective items. Seller is not liable for incidental or consequential damages of any kind.

LSV20100B Lakeshore Lift Vertical, 2000 lb. cap., 100" Beam, 54" Lift Height

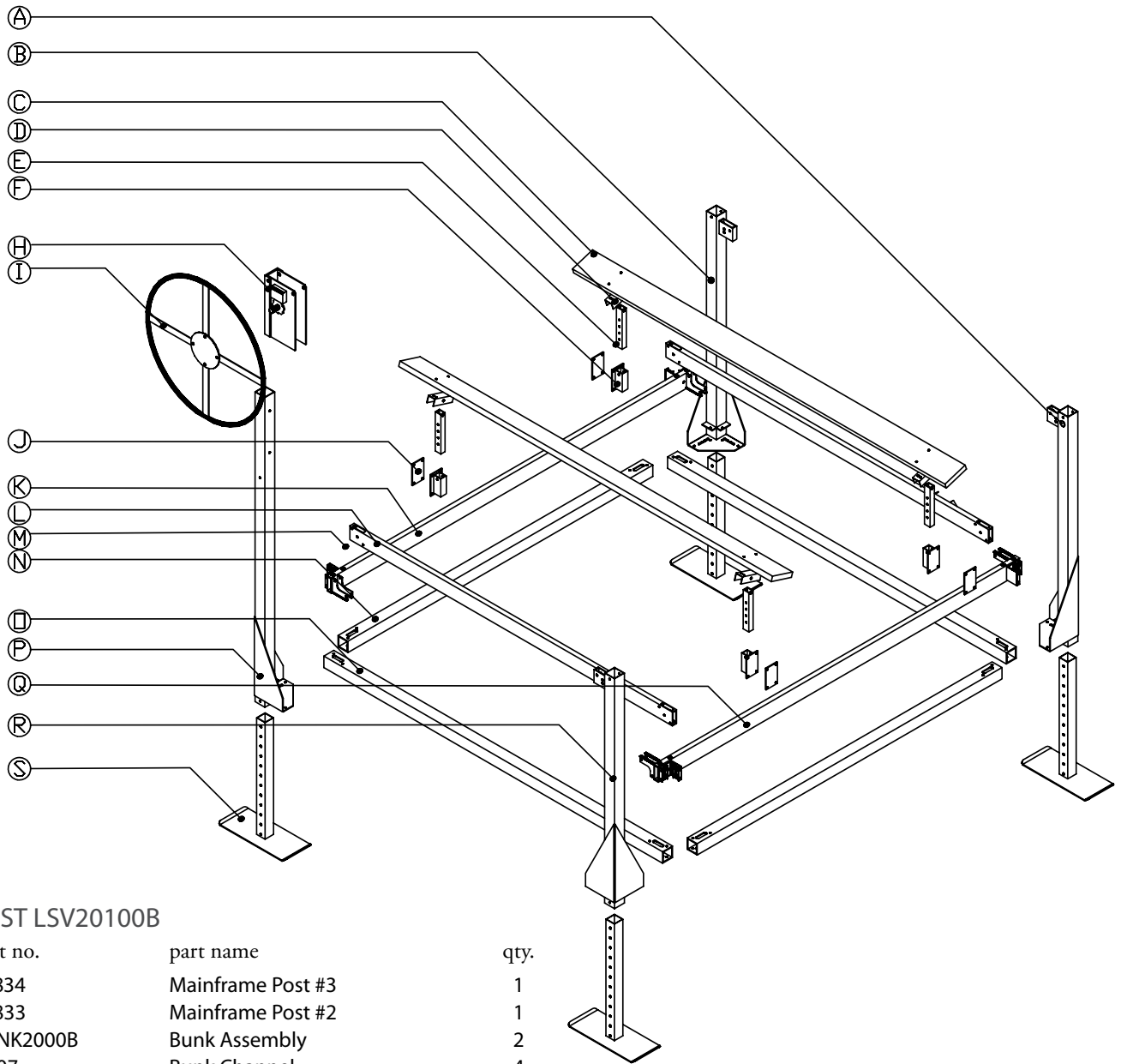

PARTS LIST LSV20100B

ref.	part no.	part name	qty.
A	20834	Mainframe Post #3	1
B	20833	Mainframe Post #2	1
C	BUNK2000B	Bunk Assembly	2
D	BU07	Bunk Channel	4
E	BDL12	Bunk Down Leg	4
F	20676	Bunk Socket	4
H	W5	3500 lb. Winch	1
I	LS2005B/20886	41" Wheel/Shaft Adapter	1/1
J	20678	Bunk Socket Plate	4
K	20877F	Cradle Front	1
L	20878	Cradle Spreader	2
M	20862	Cradle Roller Kit	4
N	20879	Mainframe Spreader 100"	2
O	20879	Mainframe Spreader 100"	2
P	20832	Mainframe Post #1	1
Q	20877R	Cradle Rear	1
R	20833	Mainframe Post #4	1
S	20835	Leg Weld Assembly 36"	4