



Owner's Manual

LSC964

900 lb, 64" Beam Jet Lift

READ CAREFULLY - FAILURE TO FOLLOW INSTRUCTIONS AND SAFETY RULES MAY RESULT IN SERIOUS INJURY

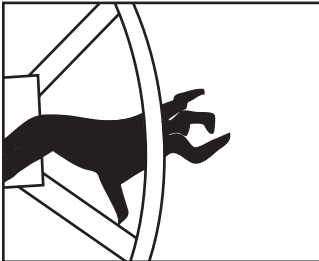

⚠ WARNING

DO NOT ATTEMPT TO STOP SPINNING WHEEL.
Serious personal injury could result.

Lift Wheel must be turned clockwise for lifting.
NEVER raise lift by turning wheel counterclockwise.
Doing so will result in an uncontrolled spin down,
which could lead to cable failure and serious injury.

Z117

⚠ CAUTION

DO NOT CRANK PAST STOP POSITION.

When raising lift be aware that when moving components contact frame you have reached maximum height.
Turning wheel past this point may cause personal injury and will cause damage to lift that is not covered by warranty.

Z119

⚠ WARNING

DO NOT OPERATE THIS HOIST WITHOUT FIRST STUDYING THE OWNER'S MANUAL.

1. Before operating this lift be sure to understand all operating procedures and safety precautions.
2. **NEVER** operate lift with people on board boat or near any part of lift.
3. **NEVER** work or play on, around or under lift.
4. **NEVER** exceed the rated capacity of lift. Doing so may cause lift to fail.
5. Before use visually inspect **SHEAVES** and **CABLE** for wear or fraying. Follow proper maintenance procedures.

Failure to follow these procedures could cause lift to fail and result in death or serious personal injury.

Z116

Manufacturers of Lakeshore Products

855 East Chicago Road, Quincy, MI 49082

www.lakeshoreproducts.com • tel: 517.639.3815 • fax: 517.639.4576

LSC964 900 lb, 64" Beam Jet Lift

With proper care and maintenance, this lift will provide you with years of trouble free service. Please follow these instructions carefully.

NOTE

Install all nuts and bolts loosely until the lift is fully assembled, then tighten all nuts and bolts properly.

Do not overtighten the nuts and bolts on your lift.

Doing so may cause the lift to fail. When tightening against a tube, tighten until the aluminum just dimples. If you crush the tube, it may crack and fail under normal use.

tools needed

adjustable wrenches	2
or	
1/2 wrenches	2
9/16 wrenches	2
3/4 wrenches	2
7/16 wrench [for winch]	1

1. mainframe setup

mainframes [right and left] w/ legs attached	2
---	---

Setup the mainframes.



2. mainframe spreader

mainframe spreader	1
bolt package step 2	1

Bolt the mainframe spreader tube between the mainframes using:

- 4 - 3/8 x 2 1/2 hex bolts
- 4 - 3/8 flat washers
- 4 - 3/8 nylon lock nuts

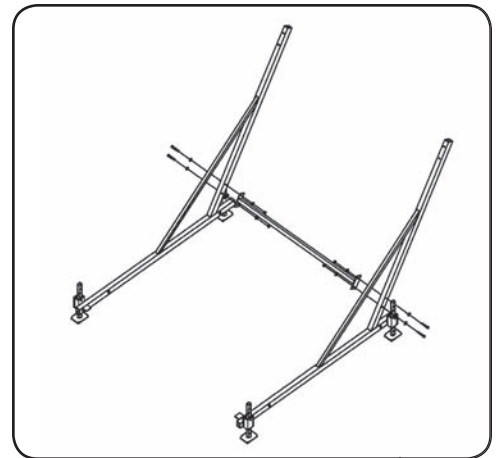

3. install H-units

H-units	2
bolt package step 3	1

Place the 2 H-units inside the mainframes and attach using:

- 4 - 1/2 x 4 1/2 hex bolts
- 12 - 1/2 flat washers
- 4 - 1/2 nylon lock nuts

Place a washer under the head of each bolt, under the nut, and between the H-unit and the mainframe. The bolts must be loose enough to allow the H-units to pivot.

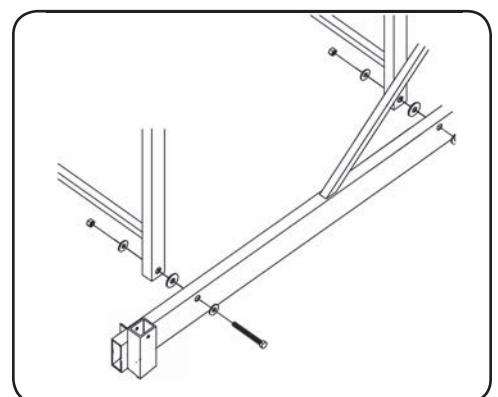

4. cradles

cradle 60.5"	2
pulley bar 63"	1
cradle spreader tube	2
cradle spreader end caps	4
bolt package step 4	1

Install a cradle and the pulley bar on top of the front H-unit and the second cradle on the rear H-unit using:

- 4 - 1/2 x 3 1/2 hex bolts
- 4 - 1/2 nylon lock nuts

Attach the cradle spreader tubes between the front and rear H-units and attach the cradle end caps using:

- 8 - 5/16 x 6 1/2 hex bolts
- 4 - angle caps
- 8 - 5/16 flat washers
- 8 - 5/16 nylon lock nuts

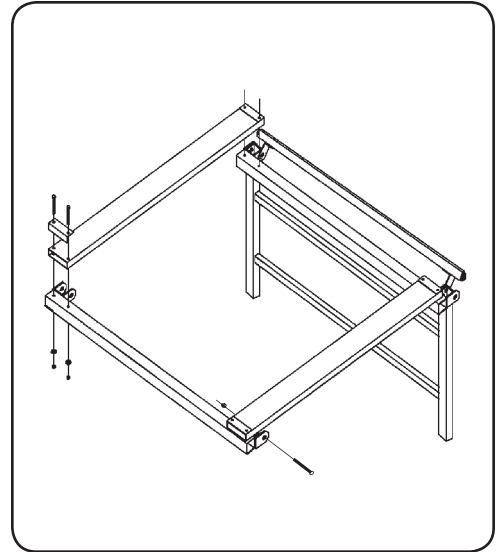

5. install winch

winch 1200#	1
red wheel 25"	1
bolt package step 5	1

Install the winch on the desired side of the lift using:

- 2 - 3/8 x 4 hex bolts
- 4 - 3/8 flat washers
- 2 - 3/8 nylon lock nut

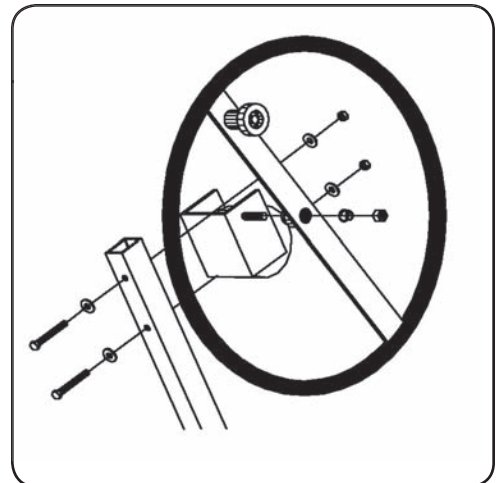

6. install wheel

CAREFULLY thread the 25" red wheel onto the winch shaft. The wheel should be able to thread on and off the shaft easily. This is the action that activates the brake mechanism.

Turn the wheel clockwise and you should here a clicking sound, this means the brake is working. This raises the lift and keeps it raised wherever you stop.

Turn the wheel counter clockwise and the brake is released allowing the lift to lower.

To keep the wheel from coming off the shaft fasten using:

- 1 - winch spring
- 1 - 1/2 jam lock nut

Tighten the nut just until 1 or 2 threads of the shaft are visible while preventing the winch shaft from turning.

NOTE

The wheel needs to thread on and off the shaft to activate the brake. This shaft should be greased yearly to ensure proper operation.

Extreme care should be taken not to cross thread and damage the threads on the wheel hub. This will void your warranty.

7. string cable

1	1
2	1

Attach the loop end of the cable to the mainframe opposite the winch using:

- 1 - 3/8 x 4 hex bolt
- 2 - 3/8 flat washers
- 1 - 1/2 flat washer
- 1 - 3/8 nylon lock nut

String the cable inside the pulley bar as shown in the exploded view (page 6). Secure it to the winch following the instructions included with the winch.

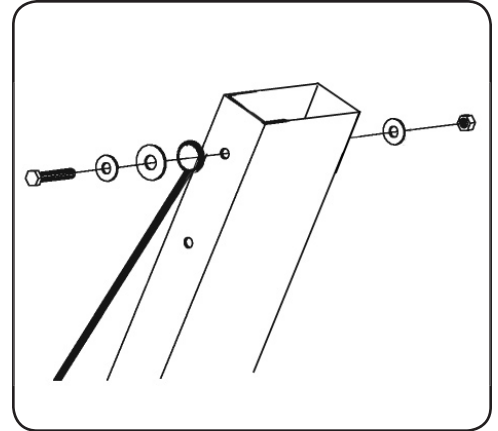

8. bunks

2	4
4	4
4	1

Attach the carpeted bunks to the front and rear cradles using:

- 4 - 5/16 x 1 hex bolts
- 8 - 5/16 x 2-1/2 hex bolts
- 12 - 5/16 lock nuts

For most uses bunks should be placed approximately 18" apart. Make sure the bunk adjustment channels are on the outside of the lift as shown.

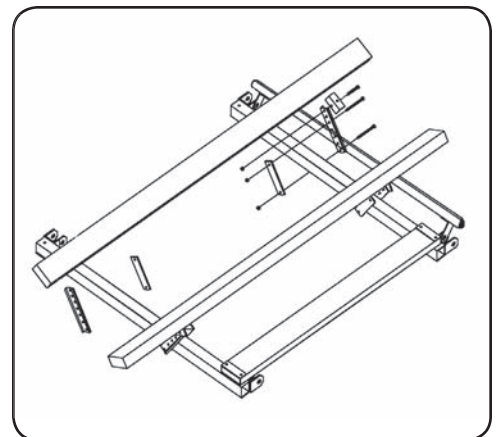

9. final adjustments

2	4
4	4

Now tighten all nuts and bolts, except the ones from Step 3 and 4 that must be free to allow the H-units to pivot.

Install the 6 red plastisol caps, 2 at the top of the mainframe and 4 on the legs.

Move your lift into the water and adjust its legs so that the lift is level. The legs can be removed to lower the lift if the water is very shallow.

Adjust the bunk height just high enough so your craft's bottom will not hit the cradle.

The installation is now complete.

NOTE

Never over crank the winch. Once the lift has reached its highest point, further cranking will damage the lift.

hints

- A. Place your lift in the deepest water you can, your lift will operate most easily at the top of its lifting range.
- B. Deep V hulls may be accommodated by moving the front of the bunks closer together and leaving the back farther apart to provide stability.
- C. In deep water? If you have a deep lake and are in need of longer legs, LSP, Inc. offers 4 foot long legs for your PWC Lift. Ask your dealer for details or call us at 517.639.3815.
- D. Greasing the cable where it wraps around the winch drum will increase cable life.

important

- A. Grease the winch shaft annually. The red wheel must be able to thread and unthread easily in order for the braking mechanism to work properly.
- B. Your LSP PWC Lift will only protect your personal watercraft if the craft is lifted well above the level of the water. In larger lakes or during storms, large waves may lift the craft from the lift or tip the lift over, causing damage both to the craft and the lift. You must take precautions to protect your craft and lift from these conditions. If your craft suffers damage from high waves, LSP, Inc. will not accept responsibility for such damage.
- C. Inspect your lift often for signs of wear or improper operation. Be aware of normal cranking force. Any increase in cranking force is a sign that something is wrong. DO NOT USE the lift if any parts are worn or damaged, replace immediately.
- D. Pay attention to the condition of your cable. A frayed or rusted cable can lead to failure of the lift. Replace it immediately. Greasing the cable, especially where it enters the winch, can extend its life.
- E. A second caution decal is provided in the accessories box. If after assembly the decal is not easily seen then install the extra decal so that anyone using the lift can read it. NEVER let anyone operate the lift unless they are familiar with all safety rules.
- F. NEVER let anyone play on, around, or under the lift.

Ten/Two Year Limited Warranty

LSP, Inc. (Seller) warrants the aluminum structure on docks and lifts of its manufacture to be free from defects caused by faulty material or poor workmanship. Seller will, at its option, repair or replace any such goods found on examination by Seller, to be defective under normal use and service within ten years from date of purchase. Upon discovery of any such defect, Buyer must notify Seller in writing of defect and provide proof of purchase. Seller warrants cast aluminum parts, mechanical components, and hardware for two years.

Seller shall not be held responsible for repairs or modifications to its docks or lifts unless authorization has been obtained from Seller. This warranty does not cover damage caused by incorrect assembly or adjustments, overloading, improper use, neglected maintenance, alterations, or damage caused by accident, ice, salt water, or acts of God.

Components obtained from other manufacturers and used in Seller's products will be covered under the manufacturer's warranty and shall not be the responsibility of the Seller.

Seller's responsibility under this warranty shall be the repair or replacement of defective items. Seller is not liable for incidental or consequential damages of any kind.

accessory package 964

bolt package with steps 1-8	1
cradle end caps	4
bunk adjustment channels	4
channel backer plates	4
1200# DL winch and booklet	1
cable with loop in one end	1
1.5" x 3" red plastisol caps	2
1.5" x 2" red plastisol caps	4

LSC964 900 lb, 64" Beam Jet Lift

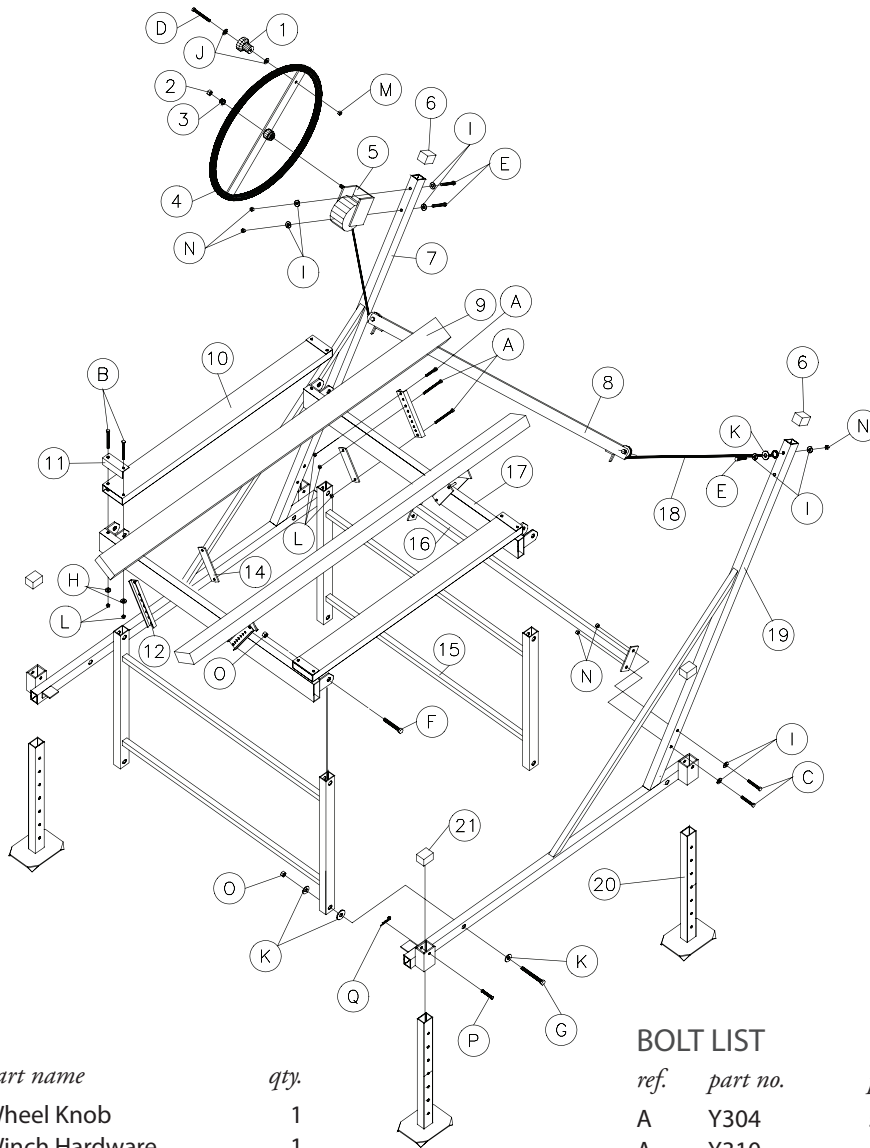

PARTS LIST

ref.	part no.	part name	qty.
1	20552	Wheel Knob	1
2/3	20498	Winch Hardware	1
4	LS1102	25" JL Wheel	1
5	20418	Dutton-Lainson DLB-1200 Winch	1
6	20462	1 1/2" x 3" Plastisol Cap	2
7	20397	Left Mainframe	1
8	20815/20682	Pulley Bar Assembly/ Hardware Only	1/1
9	20420	Carpeted Bunk	2
10	20436	Cradle Spreader Tube	2
11	20463	Cradle End Cap	4
12	20501	Bunk Adjustment Channel	4
14	20502	Bunk Backer Plate	4
15	20817	H Unit	2
16	20818	Mainframe Spreader Tube	1
17	20816	Cradle	2
18	20464	Cable 3/16" x 252"	1
19	20398	Right Mainframe	1
20	JLU	Leg	4
21	DEM12	1 1/2" x 2" Plastisol Cap	4

BOLT LIST

ref.	part no.	part name	qty.
A	Y304	5/16 x 1 Hex Bolt	4
A	Y310	5/16 x 2 1/2 Hex Bolt	8
B	Y326	5/16 x 6 1/2 Hex Bolt	8
C/D	Y410	3/8 x 2 1/2 Hex Bolt	5
E	Y416	3/8 x 4 Hex Bolt	3
F	Y514	1/2 x 3 1/2 Hex Bolt	4
G	Y518	1/2 x 4 1/2 Hex Bolt	4
H	Y352	5/16 Flatwasher	8
I	Y452	3/8 Flatwasher	10
J	X452	3/8 Stainless Flatwasher	2
K	Y552	1/2 Flatwasher	13
L	Y351	5/16 Lock Nut	20
M	Y450	3/8 Hex Nut	1
N	Y451	3/8 Lock Nut	7
O	Y551	1/2 Lock Nut	8
P	CP	3/8 x 2 1/2 Clevis Pin	4
Q	HPC	Hair Pin Cotter	4