

DC 12/24v - Direct Drive Boat Lift Motor

LAKE LIFTER: 100 Industrial Drive, Avilla IN 46710 Ph: 260-918-2758 Email: sales@lakelifter.com

IMPORTANT INFORMATION:

⚡ 12v or 24v POWER: 12v or 24v battery power only ([For best performance use 24v](#))

Unplug or turn OFF unit when not in use. Lightning & electrical surges can cause unattended operation. Powering unit OFF helps however, disconnecting the unit is the safest method of protecting the unit from damage while away.

🔌 CONNECTION: The battery wire should be less than 20ft in length for proper performance. Connect the Lake Lifter motor to a battery power source using the supplied power cable with safety FUSE and inspect regularly for good condition.

🔌 FUSE: ALWAYS use a fuse between the battery + connection and motor + wire.

If the fuse blows: Boat lift may have serious problems or motor may be faulty.

⚡ 12v or 24v POWER: Use marine deep cycle battery or AMG batteries.

Note: LiFePo4 Batteries NOT recommended due to BMS & cold weather limits issues.

⚠️ WARNING: READ AND UNDERSTAND ALL THE INSTRUCTIONS AND WARNINGS PRIOR TO USE. NEVER OPERATE LIFT WITH PERSONS IN, NEAR, OR UNDER THE BOAT OR BOAT LIFT. IMPROPER USE OF PRODUCT MAY RESULT IN DEATH, PERSONAL INJURY OR PROPERTY DAMAGE. IN THE EVENT OF UNINTENTIONAL OPERATION, IMMEDIATELY DISCONNECT THE UNIT FROM POWER SOURCE.

ONLY FOR USE BY ADULTS OVER THE AGE OF 18 YEARS.

⚠️ SAFETY: For safe operation of the Lake Lifter Motor, complete installation before connecting to a power source. Ensure the winch box is secured and safely attached to the boat lift post. Inspect motor & winch regularly for structural integrity. DO NOT install the motor on a damaged or weakened winch box. Cease operation immediately and seek professional help for replacement or repair of any damaged components.

🛢️ LUBRICATE: Frequently inspect and lubricate winch box chains & bearings to prevent excessive wear from motor use.



Lake Lifter Direct Drive Motor: Limited Warranty

The Lake Lifter Direct Drive Motor is backed by a limited warranty for consumer use, valid for 2 years from the date of retail purchase. This warranty applies only in the USA and Canada. Register your product at: www.lakelite.com/registration

We warrant that the Lake Lifter Direct Drive Motor will be free from defects in material and workmanship, subject to normal wear and tear. This warranty does not cover defects caused by (I) overloading, (II) physical abuse, (III) improper installation or use contrary to instructions, (IV) commercial use, or (V) use in saltwater.

In the event of any defects, we will repair or replace the product, at our discretion. The consumer is responsible for shipping charges to return the product to us. However, we will cover the cost of shipping the repaired or replacement unit back to the consumer.

Please note that all expedited freight charges associated with warranty claims are the responsibility of the consumer, as are any 3rd party labor charges incurred in removing, transporting, or installing the motor.

We expressly disclaim all other warranties, including express warranties, UCC implied warranties, and warranties of merchantability and fitness for purpose. We are not responsible for any consequential or incidental damage.

To expedite warranty service, please complete and return the Warranty Registration Card along with a copy of your original retail sales receipt at the time of purchase.

To submit a warranty claim, please send your name, mailing address, original sales receipt, and a summary of the alleged defect to sales@lakelifter.com. For questions regarding warranty service and claims, please call us at (260) 918-2758.

LAKE LIFTER is a registered DBA of LAKE LITE INC.



For questions, concerns, missing or damaged parts, DO NOT return to retailer: Please contact Lake Lifter Service Department.

Operating Instructions:

1. Ensure electrical cords are connected to GFCI power source and are not dangling in the water.
2. Turn the power switch to the ON position (lighted).
3. Insert Key into key switch and turn the motor UP to raise the boat lift and DN to lower the boat lift.

IMPORTANT: The motor should turn **clockwise** when lifting the boat. If the direction is opposite, then **STOP** immediately and reverse direction. The cable of the lift is wound on the drum backwards and must be corrected or serious damage may occur to winch, boat lift, or boat.

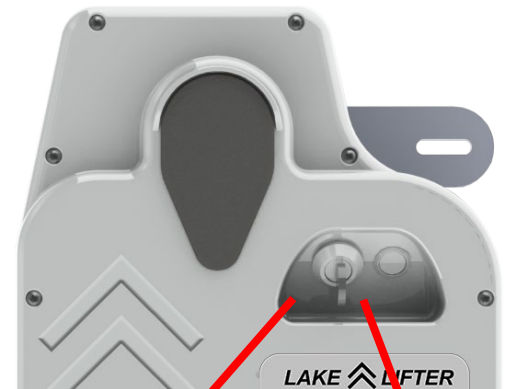

Key turn Switch

Power Switch

Remote Operation

! **IMPORTANT:** NEVER operate Key turn switch or key fob buttons at the same time. Damage will occur.

1. Press the UP button on the key fob to raise the lift.
2. Press the DN button on the key fob to lower the lift.
3. Press the LIGHT button on the key fob to activate the light (auto shut-off after 15 mins).
4. Hold the STOP button for 10s to enter programming mode (follow prompts).
5. Press the STOP button to stop the lift (only when in Auto-Run mode)

↻ **SYNC KEY FOBs:** Turn motor on, within 6 seconds hit any button on fob.
UNSYNC ALL KEY FOBs: Hold down the light button for 20 seconds.



Optional LED Lights



LED OUTPUT

Programming Limits

! **IMPORTANT:** See next page for complete instructions & warnings.

12v LED Light Output

! **IMPORTANT:** DO NOT exceed 30 watts output or the internal RF fuse may blow and or damage the circuit. Warranty voided with use of NON-Lake Lite or Lake Lifter brand LED lights. Light automatically turns off after 15:00 minutes.

Backup Drill Drive

! **IMPORTANT:** DO NOT use an impact drill: Use a standard drill in NON-IMPACT mode!

1. Use 9/16" deep well socket. Insert through hole under motor and secure onto the motor shaft.
2. Operate drill to lower or raise the boat lift.
3. **NOTE:** A powerful drill is necessary. It may be IMPOSSIBLE to raise the lift by drill with the boat on the lift.



DOWN LIMIT NOTICE:

DOWN Limit is NOT based on water depth.

The lower limit of the boat lift is not determined by water depth, but rather by the point at which the lifting cable still maintains tension and weight from the lift. This occurs just before the lift reaches the bottom and the cable becomes slack. It is crucial to ensure that the cable does not become slack at this lower limit.

CABLE MUST NOT SLACK AT LOWER LIMIT!

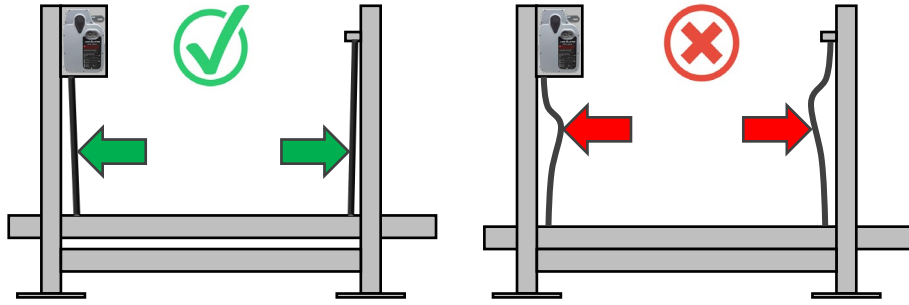

UPPER LIMIT WARNING:

User **MUST** set upper limit before the boat collides with any obstacles OR the lift's maximum lifting height. Failure to follow this important step may result in catastrophic damage to the boat, lift, cables, and/or pulleys. In such a scenario, the lift may break, causing the vessel to drop and potentially lead to property damage, serious injury, or even death. **DO NOT OVERLOOK THIS CRITICAL SAFETY ISSUE.**

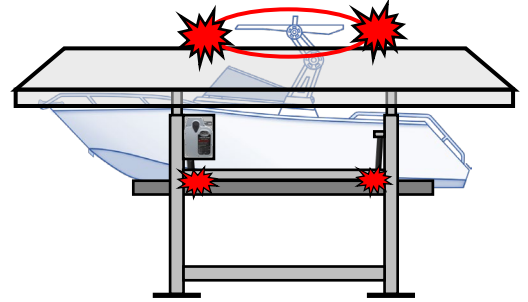

AUTO-RUN MODE – NOT PERMITTED

DO NOT enter Auto-Run mode if the upper limit is set with a lowered Tower or Bimini. User may forget to lower Tower or Bimini and the motor will **NOT STOP**. Collision & damage will occur at user's expense.

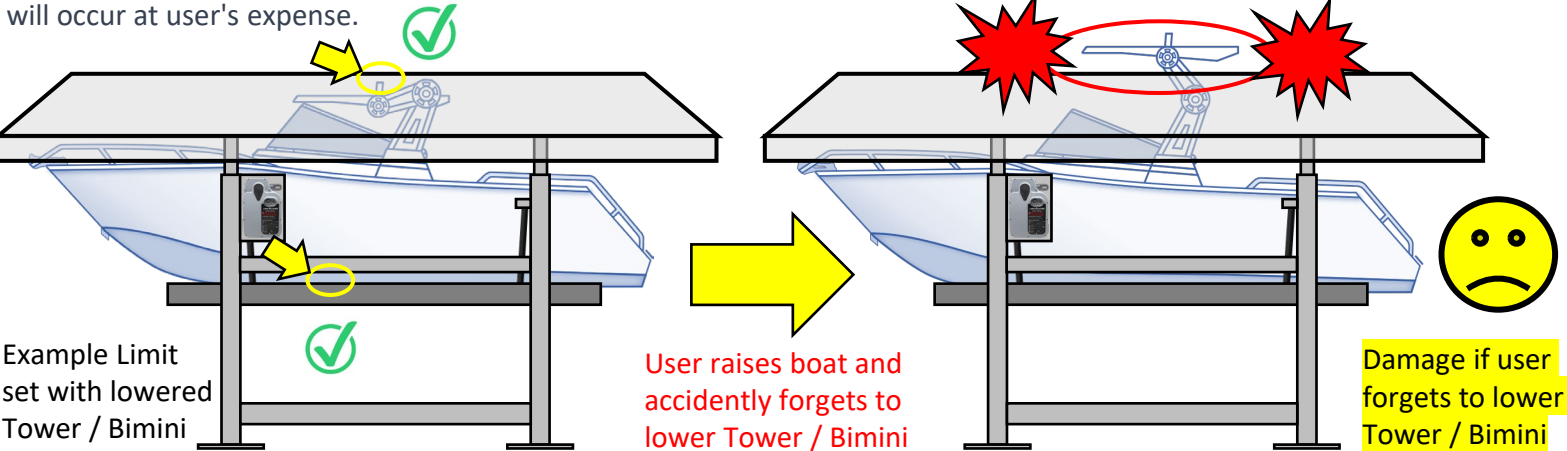

AUTO-RUN MODE – PERMITTED

Auto-Run mode may be used if the upper limit accounts for Tower and Bimini clearance, eliminating the need for the user to lower them before lifting to the limit.

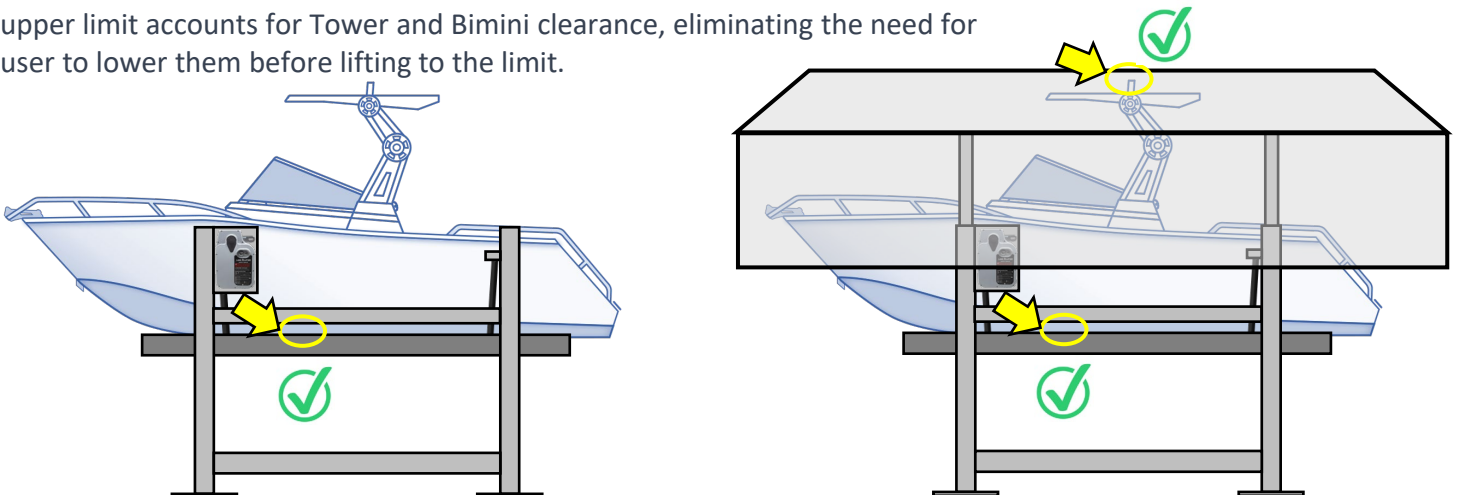

Programming Digital UP & DN Limits (Auto-Stop)



Programming UP & DN Limits: Hold the stop button on the key fob (approximately 10-seconds) until voice-prompted "Programming Mode Active". Use the UP or DN buttons to move the lift to the 1st position & hit stop and wait for voice-prompt, "The first limit is now set." Use the UP or DN buttons to move the lift to the 2nd position and then hit the stop button again to set the second limit, then confirmed with voice-prompt, "Congratulations". The boat lift will now only operate between these two limits.

IMPORTANT: AUTO STOP is activated after BOTH limits are set. Lift will only operate between these Limits: NEVER operate lift outside its travel limits. Each lift's operating range is different. User must know where to set limits & when to stop lifting or lowering to prevent damage to boat lift or vessel.

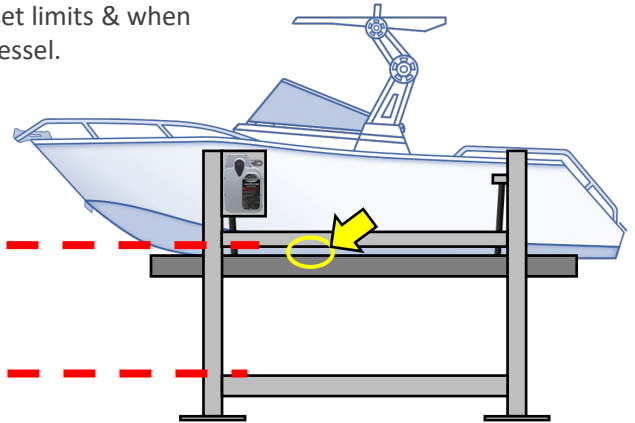
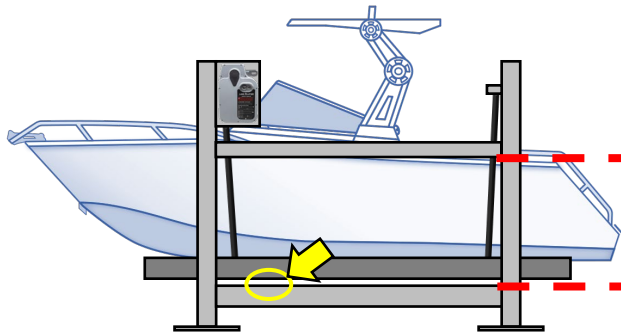
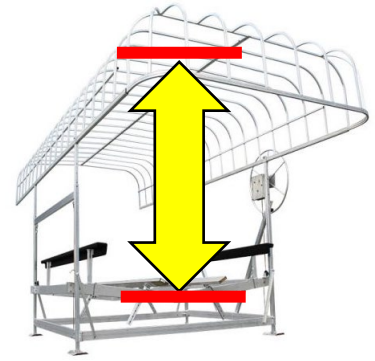

IMPORTANT AUTO RUN MODE WARNINGS:

AUTO RUN Mode is NOT for everyone! DO NOT use Auto Run mode if you have a Bimini top or wake tower that requires lowering to reach the upper limit set in the above process. Forgetting to lower the Bimini or wake tower could result in serious damage to the boat, boat lift, cables, lift motor, causing serious injury or death.



NOTE: AUTO RUN MODE (INCLUDES AUTO STOP): (LIMITS MUST FIRST BE SET)

- Turn system power switch OFF
- Simultaneously turnkey switch to the UP position and then turn power ON.
- After unit powers on release key switch, voice-prompt confirms 'Caution Auto Run Mode Now Active'.

IMPORTANT: Operating the boat lift in **AUTO RUN** mode carries inherent risks. In the event of any problem with the lift or motor, the user will have a DELAYED response to stopping. It is the responsibility of the user to assume ALL risks associated with operating the boat lift in AUTO RUN mode, including but not limited to motor malfunction, lift collisions, issues with limits or sensors, and any other unknown causes related to the hoisting of the vessel.

- 1. USER MUST REMAIN NEAR, WATCHING, & PAY CLOSE ATTENTION DURING OPERATION IN AUTO RUN MODE: NEVER WALK AWAY. ALWAYS PAY CLOSE ATTENTION WHILE OPERATING. ALWAYS BE AWARE OF SURROUNDINGS, PERSONS, POTENTIAL RISKS & PROBLEMS THAT MAY ARRISE DURING OPERATION.**
- 2. USER MAY HAVE DELAYED RESPONSE TO STOPPING THE LIFT OR OPERATION WHILE OPERATING IN AUTO RUN MODE. NEVER OPERATE THE LIFT WITH PERSONS IN, NEAR, OR UNDER THE BOAT LIFT. SERIOUS INJURY OR DEATH MAY OCCUR. USER WILL HAVE DELAYED RESPONSE TO STOP THE OPERATION IN AUTO RUN MODE.**



SENSOR FAILURE: For safety, In case of sensor failure, the motor will automatically stop, sound alarm and voice warning if the sensor is not detected within 1.2s of operation. The system assumes there is a problem with the sensor, such as a failed sensor, broken wire, or a missing/detected magnet. The voice warning will indicate that all limits have been deleted, and the unit will return to normal run mode without any limits. **The user must fix the sensor or magnet issue and reset the limits before re-entering Auto Run mode.**